

SW80 SERIES OF D.C. CONTACTORS

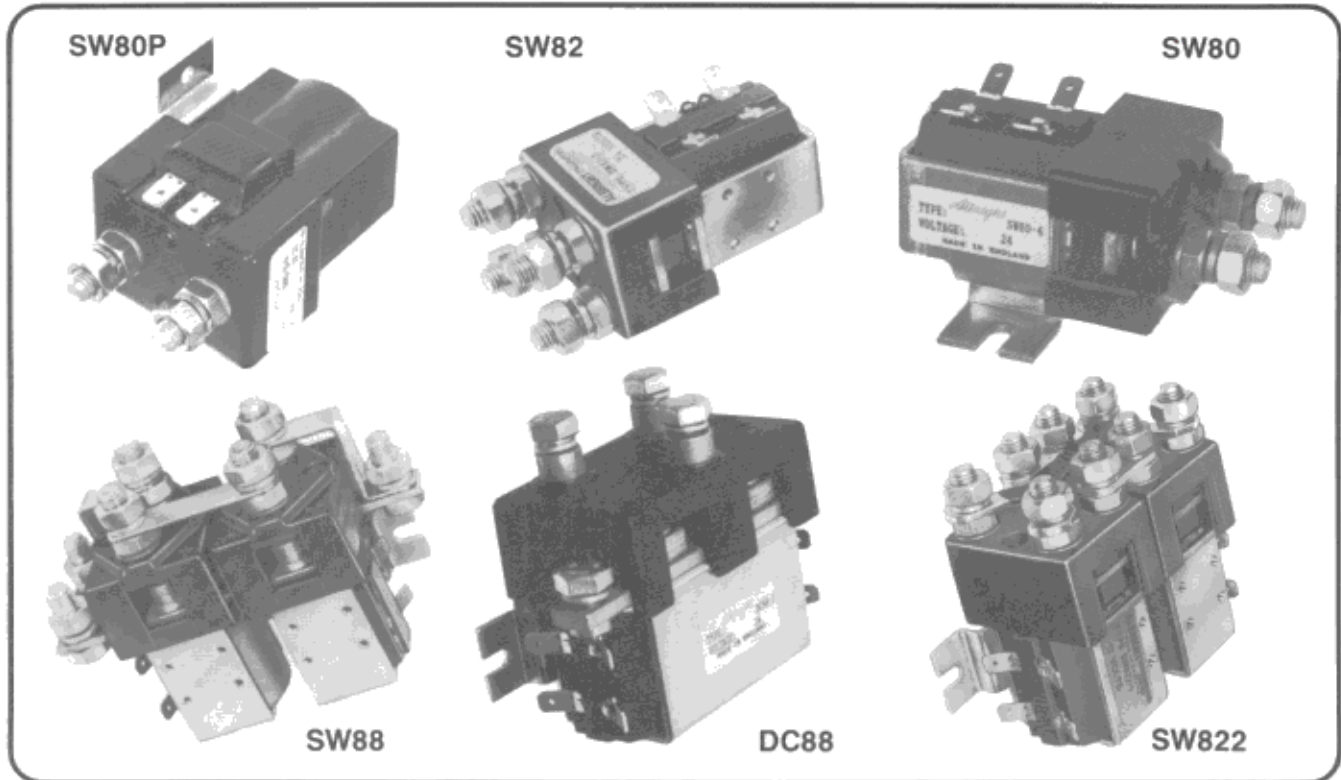

CONTACTORS IN THE SERIES

| | |
|--------|---|
| SW80 | SINGLE POLE SINGLE THROW |
| SW80P | SINGLE POLE SINGLE THROW (environmentally protected) |
| SW82 | DOUBLE POLE SINGLE THROW |
| SW82P | DOUBLE POLE SINGLE THROW (environmentally protected) |
| SW822 | PAIRED DOUBLE POLE SINGLE THROW (for motor reversing) |
| SW822P | PAIRED DOUBLE POLE SINGLE THROW FOR MOTOR REVERSING (environmentally protected) |
| SW84 | SINGLE POLE DOUBLE THROW |
| SW85 | SINGLE POLE SINGLE THROW (normally closed) |
| SW85P | SINGLE POLE SINGLE THROW (normally closed, environmentally protected) |
| SW86 | 2 x SW84 ON DOUBLE BRACKET |
| DC88 | MONOBLOCK SINGLE POLE DOUBLE THROW (for motor reversing) |
| DC88P | MONOBLOCK SINGLE POLE DOUBLE THROW (for motor reversing, environmentally protected) |
| DC88E | MONOBLOCK SINGLE POLE DOUBLE THROW (for motor reversing, reduced specification) |
| SW88 | PAIRED SINGLE POLE DOUBLE THROW ON DOUBLE BRACKET (for motor reversing) |
| SW90 | SW80 & SW84 ON DOUBLE BRACKET |
| DC92 | MONOBLOCK 2 x SW80 |
| DC92P | MONOBLOCK 2 x SW80P (environmentally protected) |
| DC92E | MONOBLOCK 2 x SW80 (reduced specification) |
| SW92 | 2 x SW80 ON DOUBLE BRACKET |
| SW93 | 2 x SW85 ON DOUBLE BRACKET |

UNIQUE RANGE

The SW80 series of contactors has been designed for direct current loads, particularly motors as used on small electric vehicles such as light industrial trucks, powered invalid cars, etc.

They have double breaking main contacts with silver alloy contact tips, which are weld resistant, hard wearing and have excellent conductivity.

The range comprises: Single Pole, on/off types (SW80), Double Pole, on/off types (SW82), Single Pole normally closed types (SW85) and paired versions of these for motor reversing (SW822, SW88 and DC88 types).

COMPACT SIZE

The contactors are compact in size and are fully serviceable, excluding 'P' versions, with a full range of spare parts available.

They are economical in price and compare favourably with sealed automotive style solenoid switches which cannot be serviced or inspected for contact wear.

EASY INSTALLATION

Mounting is by means of 4mm tapped holes in the switch frame together with a range of mounting brackets complete with screws and washers.

Coil connections are by means of 6mm spades of which two are supplied per terminal.

Contactors types DC88, DC92, SW822, SW86, SW88, SW90, SW92 and SW93 are supplied as an assembly which includes a double mounting bracket as a standard feature.

Mounting attitudes are detailed in the drawings on the following pages.

OPERATING COILS

Coil voltages ranging from 6 to 240 are available and these are wound for D.C. operation.

However, coils can be fitted with a bridge rectifier for use from A.C. supplies.

Coils are normally wound for intermittent duty (up to 70% "on" time) but continuous duty versions (100%) are also available.

continued on page 3

DIMENSION DRAWINGS

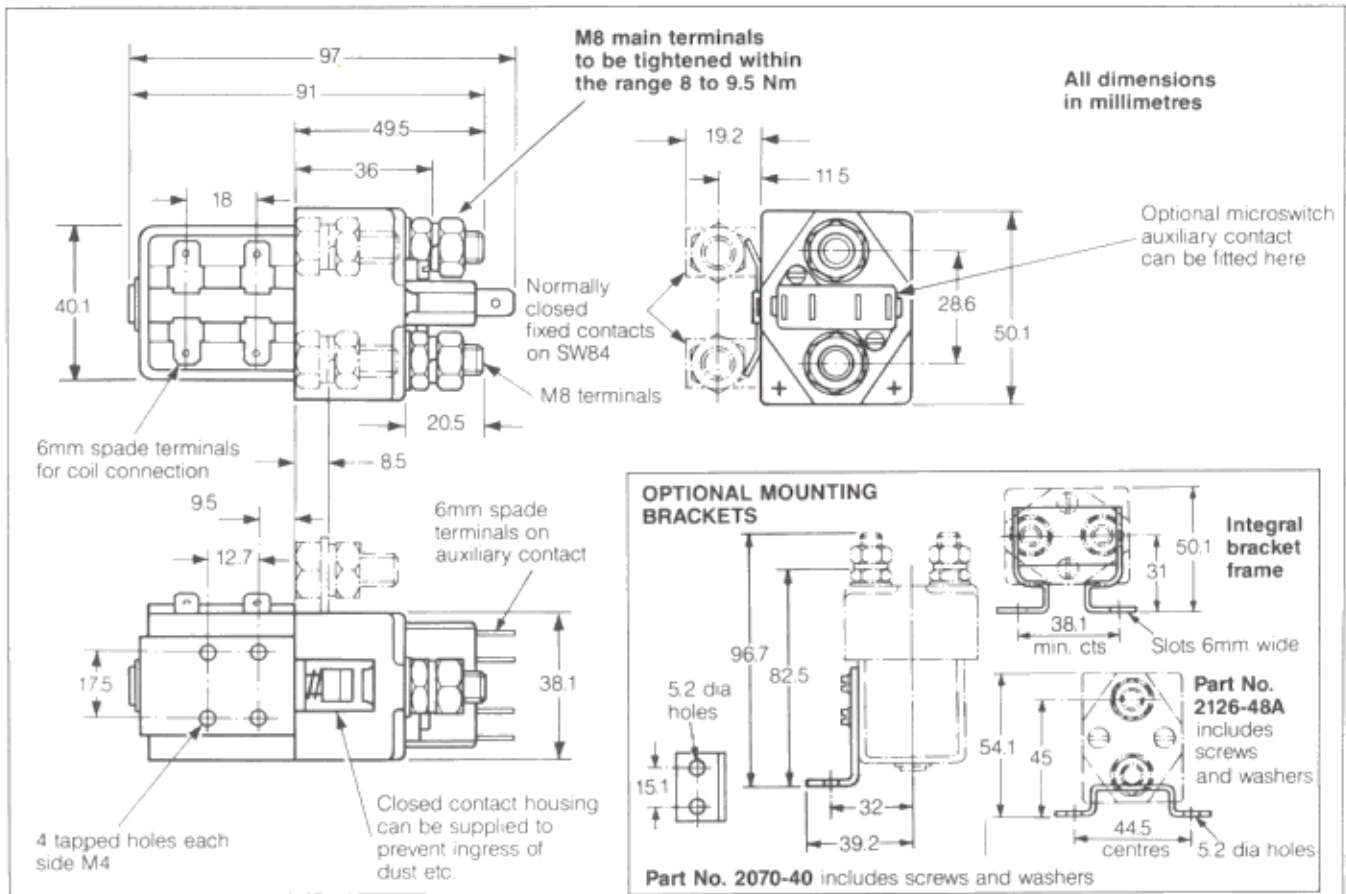

SW80, 84 AND 85

The contactors can be mounted either horizontally or vertically. If mounted vertically the contact studs must point upwards with the exception of the SW85 and its derivatives which should be mounted with the contact studs pointing downwards.

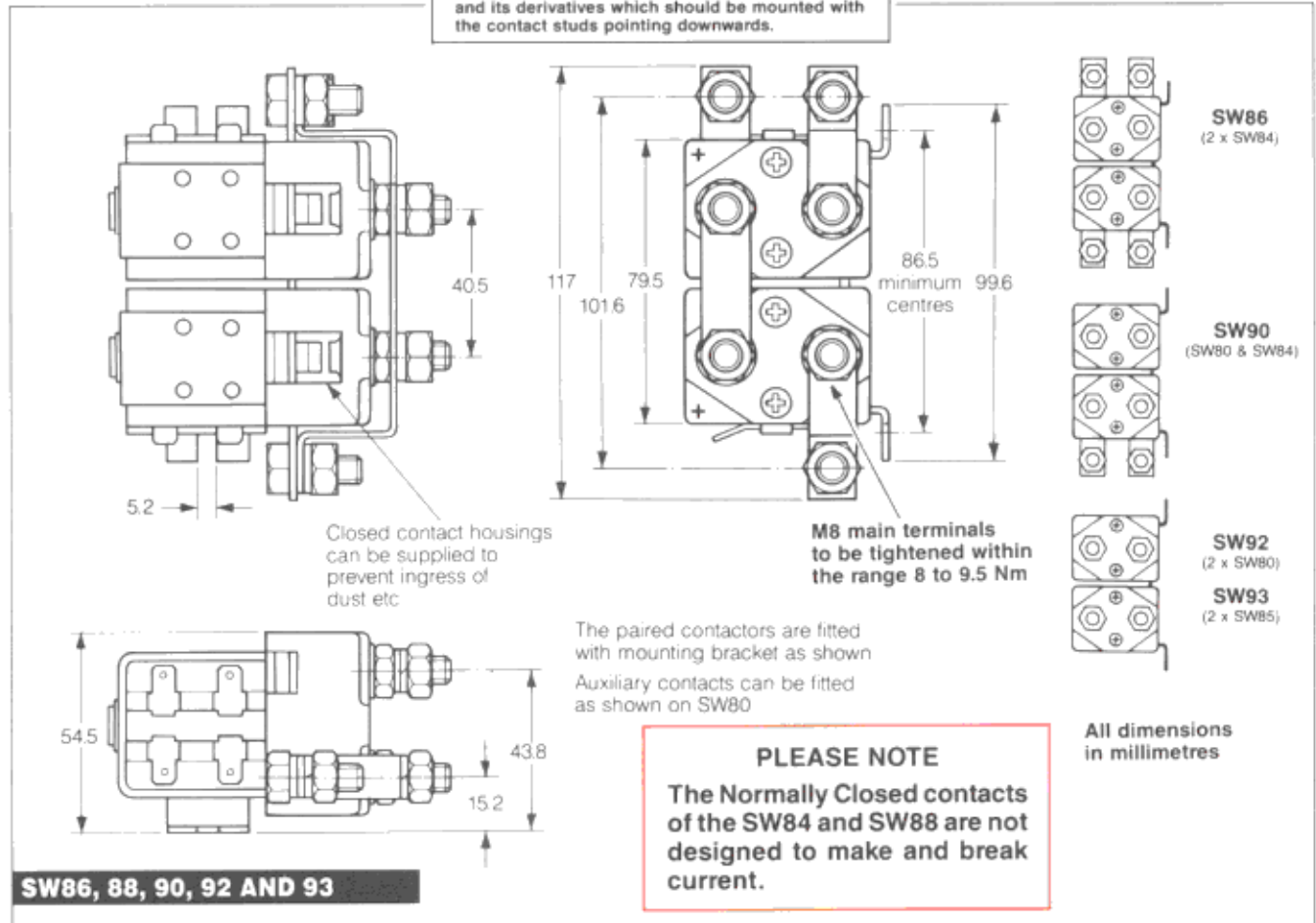

PLEASE NOTE

The Normally Closed contacts of the SW84 and SW88 are not designed to make and break current.

SW86, 88, 90, 92 AND 93

DIMENSION DRAWINGS

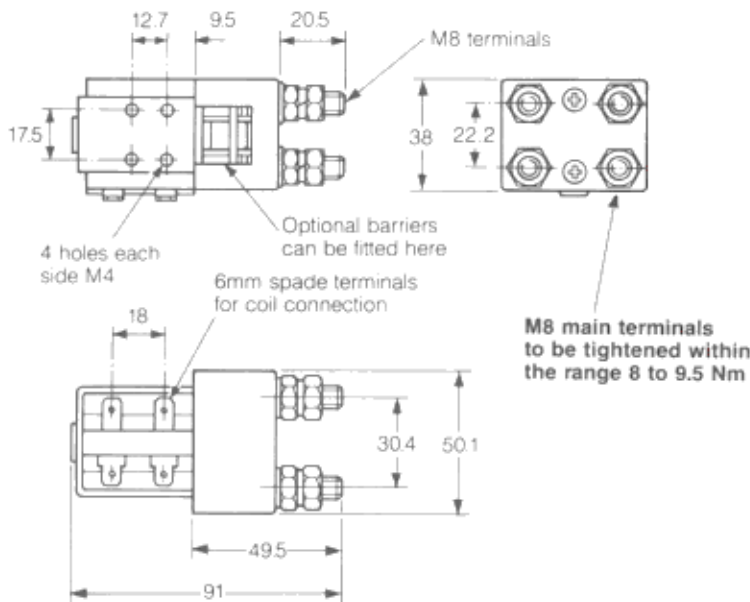

All dimensions
in millimetres

SW82

The contactors can be mounted either horizontally or vertically. If mounted vertically the contact studs must point upwards.

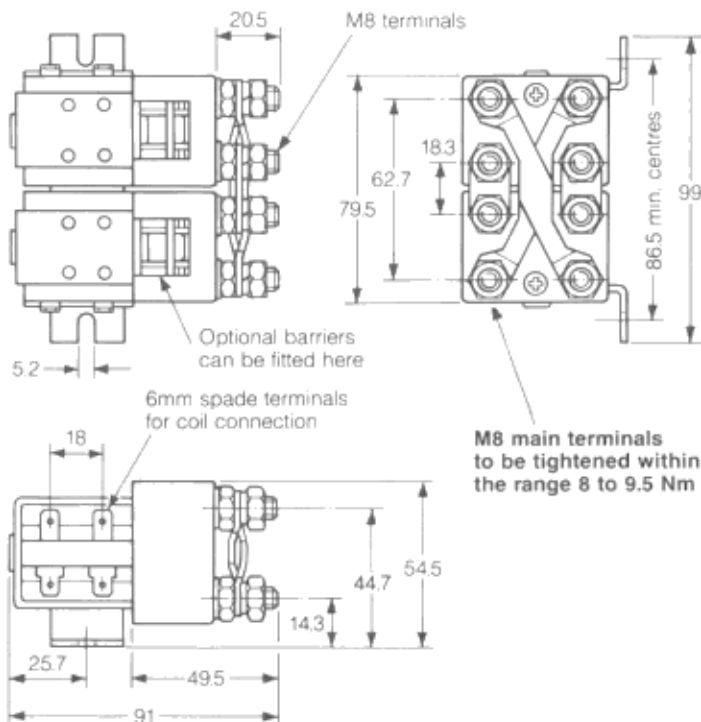

All dimensions
in millimetres

SW822

Pull-in voltages are approximately 60% and 66% of the rated voltage for intermittent and continuously rated types respectively.

Drop-out voltage is normally 10% of rated voltage.

Variations from these pull-in and drop-out figures can be engineered to suit particular applications.

CONTACTOR PAIRS

The contactors can be mounted in pairs on a common bracket together with inter-connecting electrical links. The most important of these arrangements are the motor reversing circuits provided by the SW88, DC88 and SW822 contactor pairs.

The SW88 and DC88 types have a built in failsafe so that if both coils are energised simultaneously the contact design creates an open circuit situation.

The SW822 types have fast drop-out times (approx 5 m.sec.) and relatively slow pull-in times (approx 20 m.sec). Therefore motor direction changes can be undertaken without risk of all contacts being closed at the same time. However, certain types of coil suppression such as diodes substantially increase drop-out times and care must be taken to ensure suitable suppression is fitted, e.g. diode and resistor in series.

MAGNETIC BLOWOUTS 'B'

The single pole types (excluding 'P' versions) can be fitted with permanent magnet blowouts. These enable the contacts to switch D.C. voltages of 48 or higher. Fitting of blowouts makes the contacts polarity sensitive and the **Positive markings** on the top cover of the contactor **must** be observed. The suffix 'B' denotes the fitting of magnetic blowouts, for example SW80B.

AUXILIARY CONTACTS 'A'

A double circuit normally open, normally closed microswitch can be fitted which has a D.C. resistive rating of 5 Amperes at 24v.

The suffix 'A' should be added to the type number when an auxiliary contact is required, for example, SW80A.

Note: Auxiliary contacts cannot be fitted to the SW82 or SW822 types.

DIMENSION DRAWINGS

SW80P & SW85P

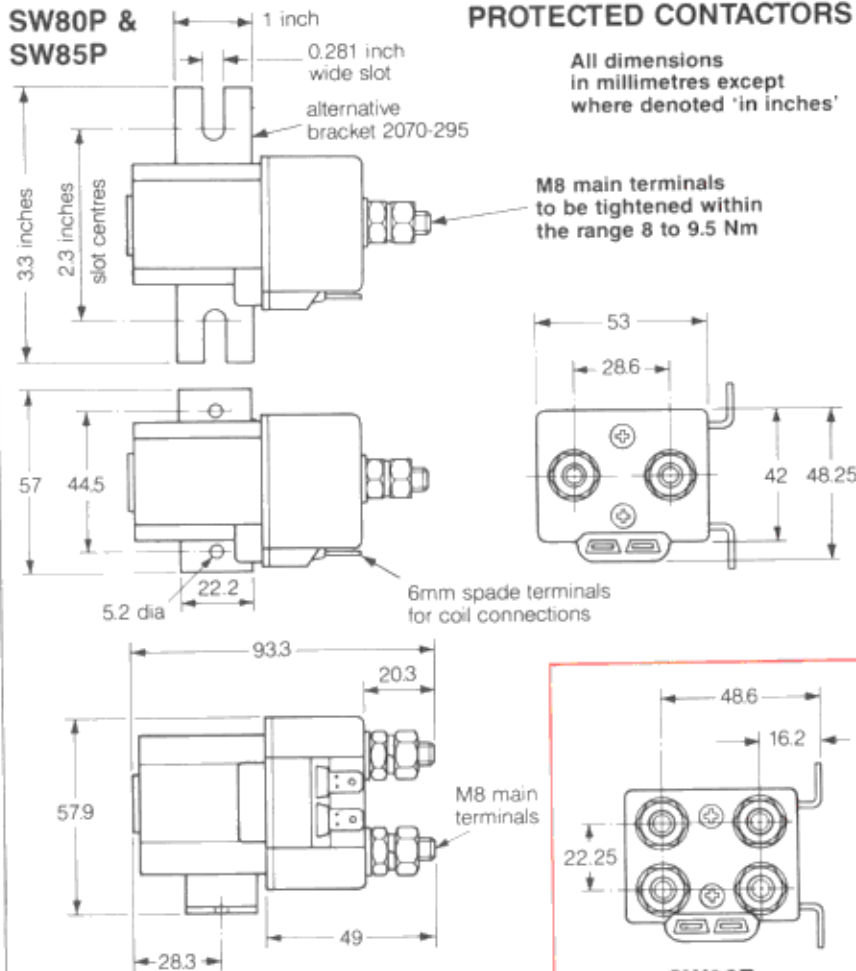

PROTECTED CONTACTORS

All dimensions in millimetres except where denoted 'in inches'

M8 main terminals to be tightened within the range 8 to 9.5 Nm

6mm spade terminals for coil connections

M8 main terminals

SW82P

SW80P, SW82P AND SW85P

The contactors can be mounted either horizontally or vertically. If mounted vertically the contact studs must point upwards with the exception of the SW85 and its derivatives which should be mounted with the contact studs pointing downwards.

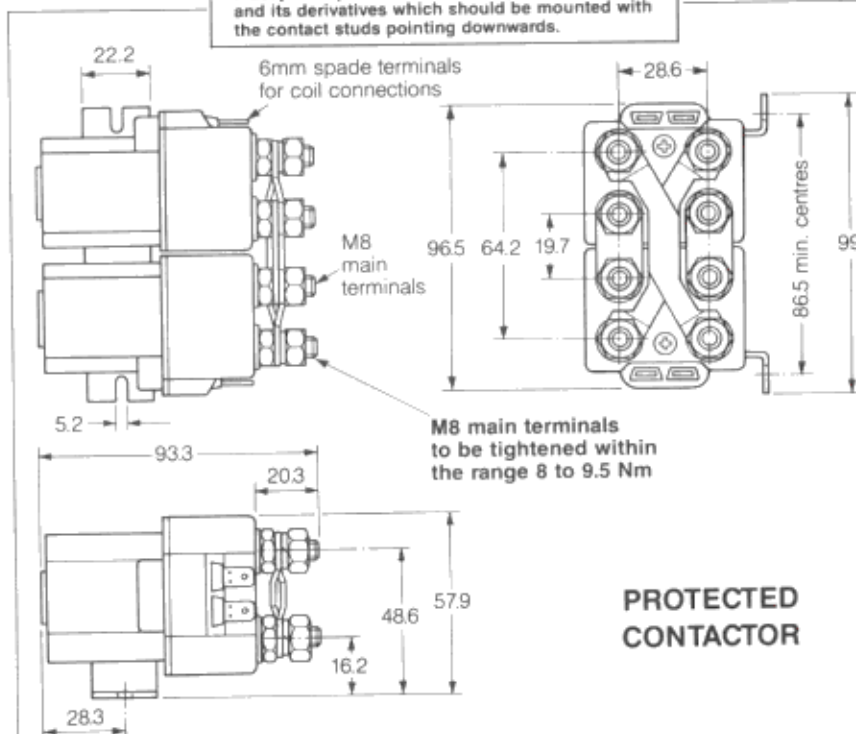

PROTECTED CONTACTOR

All dimensions in millimetres

SW82P

LARGE CONTACTS 'L'

The SW80 range of contactors have standard contacts which are 8mm diameter. These are suitable for the majority of applications where switching conditions are relatively light, particularly on electronically controlled vehicles. However, in applications where more severe conditions exist, e.g. pump motor switching, all types are available with larger contacts 10.3mm diameter. The suffix 'L' denotes larger contacts.

PROTECTED CONTACTORS 'P'

All types can be fitted with closed contact housings as a low cost option to provide protection against environmental dust.

However, special versions of the DC88, DC92, SW80, SW82, SW85 and SW822 contactors are available which are protected to IP66 against particularly adverse environments such as water spray, airborne dust, etc. These contactors, which have the suffix 'P', are sealed in an inert plastic case and are fitted with mounting brackets as shown in the drawings. Magnetic blowouts cannot be fitted to these types and therefore under normal circumstances the maximum voltage which can be switched by the DC88P, DC92P, SW80P and SW85P is 48v D.C. although the types SW82P and SW822P, by virtue of their double pole configuration, may be used up to 96v D.C.

Auxiliary contacts can be fitted to the SW80P and SW85P but some loss of protection will result.

DC88 & DC92 CONTACTORS

The DC88 is another version of a reversing contactor for D.C. motors. It has a monoblock construction and it comprises two single pole changeover contactors configured in such a way so that all the necessary links for D.C. motor reversing applications are contained within the contact housing.

This results in a neat compact design which is compatible with modern electronic control systems.

The main terminals can be configured in a variety of ways in order to suit the application layout.

All the features described in this brochure for the other contactors in the SW80 range apply to the DC88.

continued on page 6

DIMENSION DRAWINGS

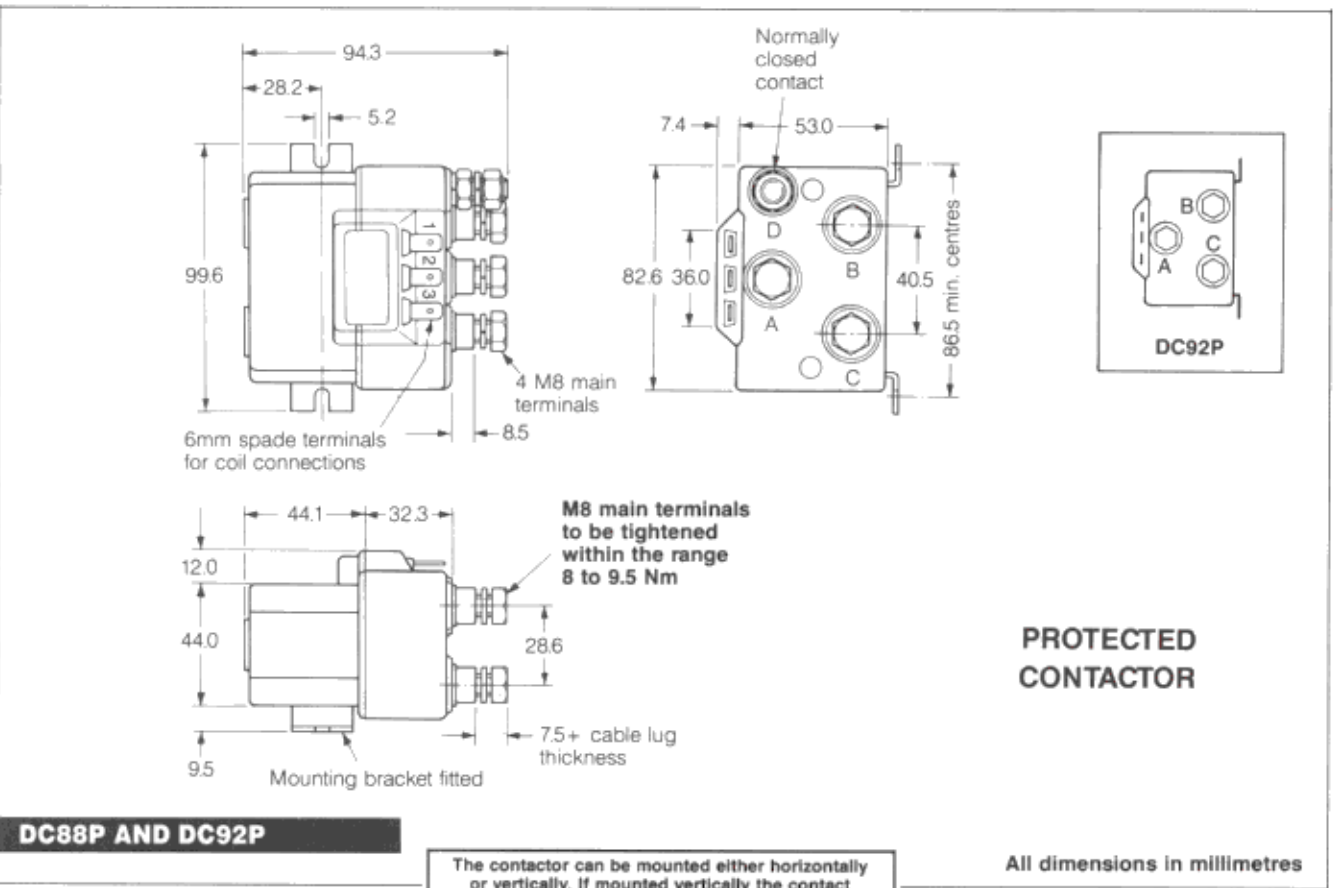
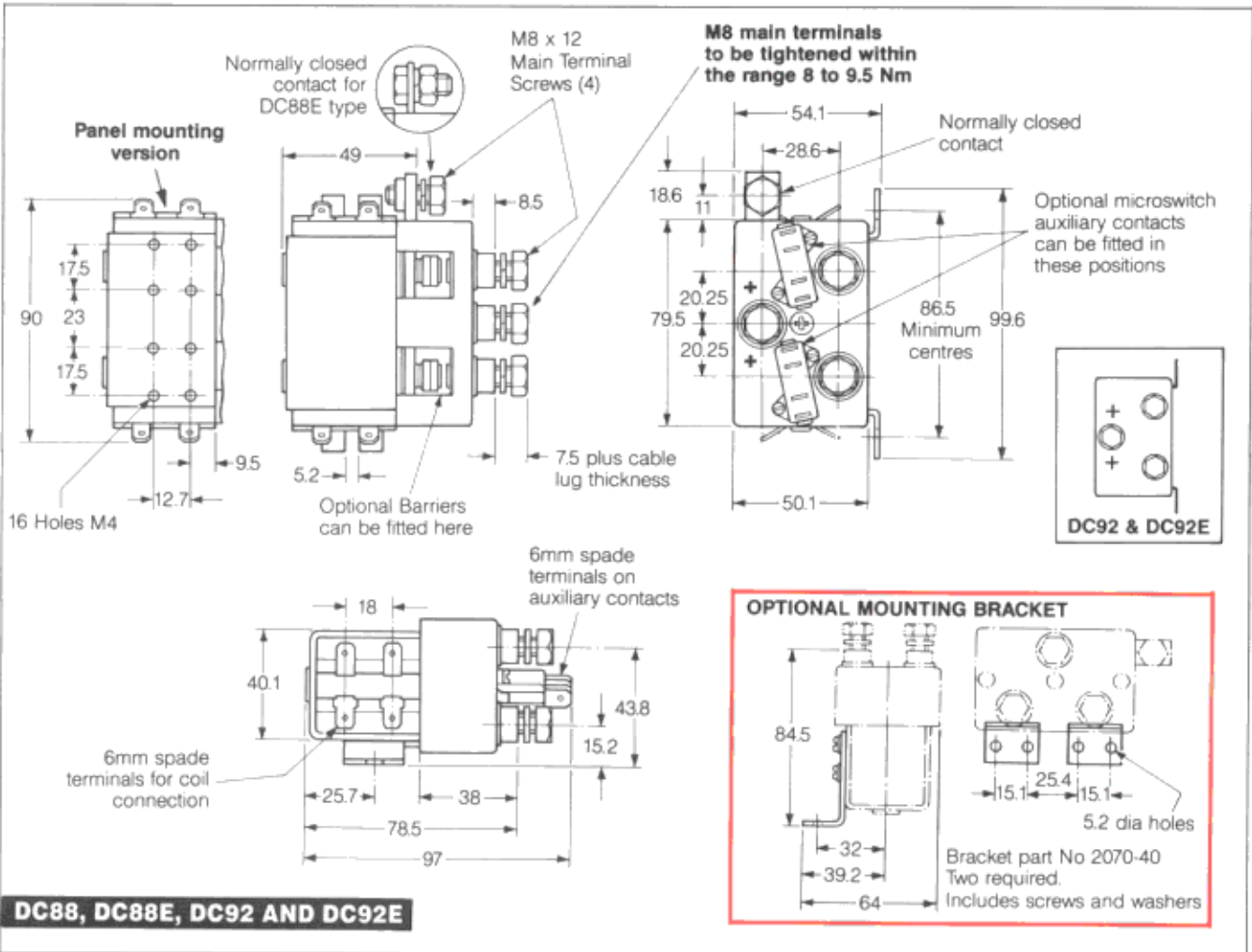

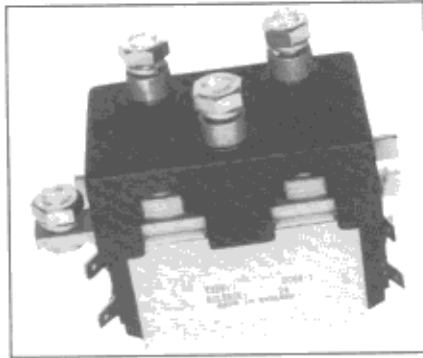

Similarly all the optional extras listed apply:

- Magnetic blowouts (suffix B)
- Auxiliary contacts (suffix A)
- Large contact tips (suffix L)

A variety of methods for mounting the contactor are available:

- (1) An integral bracket. (2) Tapped holes in the contactor frame for

A paired single pole on/off contactor can also be supplied. This is the type DC92 and this contactor can also have integral links for the main poles if required.

direct panel mounting. (3) Separate brackets for mounting the contactor at 90° to a panel (see page 5).

The DC88 is physically and electrically interchangeable with the SW88 reversing contactor.

DC88E AND DC92E ECONOMY CONTACTORS

The DC88E is a version of the DC88 Direction Contactor and has a reduced specification compared with the standard DC88.

It has been designed for use with smaller pedestrian and rider electric trucks, particularly those equipped with electronic controls. It is also intended for use with small electric winches, cranes, etc.

Thermal current rating is nominally 80A and coil power has been reduced to within the range of 10-15 watts compared with the 15-20 watts of the standard version.

This reduced specification results in a lower price which can compare

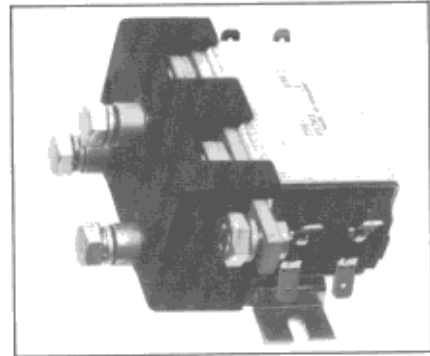

favourably with the price of automotive canned solenoids together with their associated wiring and mounting costs.

Similarly the DC92E Economy Version of the DC92 paired on/off contactor is also available.

Most of the additional features which can be specified on the standard DC88 and DC92, such as magnetic blowouts, auxiliary contacts, dust shields, etc., can also be specified for the DC88E and DC92E. Similarly, overall dimensions, footprint and terminal sizes are unchanged.

CONTACTOR WEIGHTS

Add 20 gms for each auxiliary contact

Add 50 gms for each set of blowout magnets.

| | | | | | | | | | |
|-------|---------|--------|---------|-------|---------|-------|---------|-------|---------|
| SW80 | 350 gms | SW822 | 920 gms | SW85P | 395 gms | DC88E | 930 gms | DC92 | 770 gms |
| SW80P | 390 gms | SW822P | 960 gms | SW86 | 890 gms | DC88P | 990 gms | DC92E | 750 gms |
| SW82 | 430 gms | SW84 | 430 gms | SW88 | 910 gms | SW90 | 810 gms | SW93 | 750 gms |
| SW82P | 450 gms | SW85 | 360 gms | DC88 | 950 gms | SW92 | 730 gms | DC92P | 810 gms |

EXPLANATION OF CONTACTOR TYPE NUMBERS

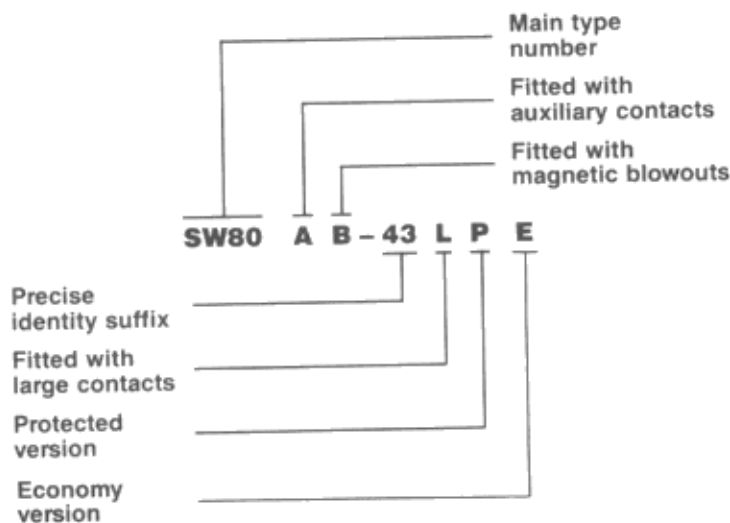

| | Auxiliary Contacts | Magnetic Blowouts | Mounting Brackets | Large Contact Tips | Closed Contact Housing | Environmentally Protected |
|-------|--------------------|-------------------|-------------------|--------------------|------------------------|---------------------------|
| SW80 | O | O | O | O | O | O |
| SW82 | N | N | O | O | O | O |
| SW822 | N | N | S | O | O | O |
| SW84 | O | O | O | O | O | N |
| SW85 | O | O | O | O | O | O |
| SW86 | O | O | S | O | O | N |
| DC88 | O | O | S | O | O | N |
| DC88E | O | O | S | N | O | N |
| DC88P | N | N | S | O | S | S |
| SW88 | O | O | S | O | O | N |
| SW90 | O | O | S | O | O | N |
| DC92 | O | O | S | O | O | N |
| DC92E | O | O | S | N | O | N |
| DC92P | N | N | S | O | S | S |
| SW92 | O | O | S | O | O | O |
| SW93 | O | O | S | O | O | O |

O = Optional Extra, S = Standard Feature, N = Not Available

COIL RESISTANCES FOR POPULAR VOLTAGES

| | 12V DC | 24V DC | 36V DC | 48V DC | 60V DC | 72V DC | 80V DC |
|-----------------------------------|--------|--------|--------|--------|--------|--------|--------|
| Intermittently rated coils (ohms) | 9 | 29 | 73 | 120 | 212 | 305 | 365 |
| Continuously rated coils (ohms) | 14 | 52 | 120 | 212 | 305 | 458 | 600 |

PERFORMANCE DATA

SW80, SW80B, SW82, SW84B, SW85, SW85B, SW88, SW88B, DC88, DC88B and SW822

Thermal current rating (100%): 100 Amperes

Intermittent current rating:

| | |
|----------|-------------|
| 30% duty | 180 Amperes |
| 40% duty | 160 Amperes |
| 50% duty | 150 Amperes |
| 60% duty | 130 Amperes |
| 70% duty | 120 Amperes |

Typical fault currents which can be ruptured (5ms time constant):

SW80 and SW85 800 Amperes at 48V D.C.
SW80B and SW85B

800 Amperes at 80V D.C.

SW84*, SW88* and DC88*

800 Amperes at 48V D.C.

SW84B*, SW88B* and DC88B*

600 Amperes at 80V D.C.

SW82 and SW822 800 Amperes at 80V D.C.

* Normally open contacts, not normally closed contacts.

Maximum recommended contact voltages:

| | |
|------------------------|----------|
| SW80(P) and SW85(P) | 48V D.C. |
| SW80B | 96V D.C. |
| SW84, SW88 and DC88(P) | 48V D.C. |
| SW84B, SW88B and DC88B | 96V D.C. |
| SW82(P) and SW822(P) | 96V D.C. |

Typical voltage drop across contacts per 100 Amperes:

| | |
|--|------|
| SW80(P) and SW85(P) | 40mV |
| SW82(P) and SW822(P) (per pole) | 50mV |
| SW84, SW88 and DC88 (P) (normally open contacts) | 40mV |
| SW84, SW88 and DC88 (P) (normally closed contacts) | 50mV |

Mechanical life: $> 5 \times 10^6$

Coil power dissipation:

| | |
|----------------------------|-------------|
| Intermittently rated types | 15-20 Watts |
| Continuously rated types | 7-13 Watts |

Maximum pull-in voltage (coil at 20°C):

| | |
|----------------------------|------|
| Intermittently rated types | 60%V |
| Continuously rated types | 66%V |

Typical drop-out voltage: 10-25%V

Pull-in time (n/o contacts to close): 20ms

Drop-out time (n/o contacts to open):

| | |
|--|--------|
| Without suppression | 5ms |
| With diode suppression | 50ms |
| With diode and resistor (depending on value) | 8-20ms |

Main contact changeover time (SW84, SW88 and DC88)

| | |
|----------------------------------|-----|
| Normally closed to normally open | 7ms |
| Normally open to normally closed | 4ms |

Typical contact bounce period: 3ms

Auxiliary contact thermal current rating:

5 Amperes

Auxiliary contact switching capacities

(resistive load):

| |
|-------------------|
| 5A at 24V D.C. |
| 2A at 48V D.C. |
| 0.5A at 240V D.C. |

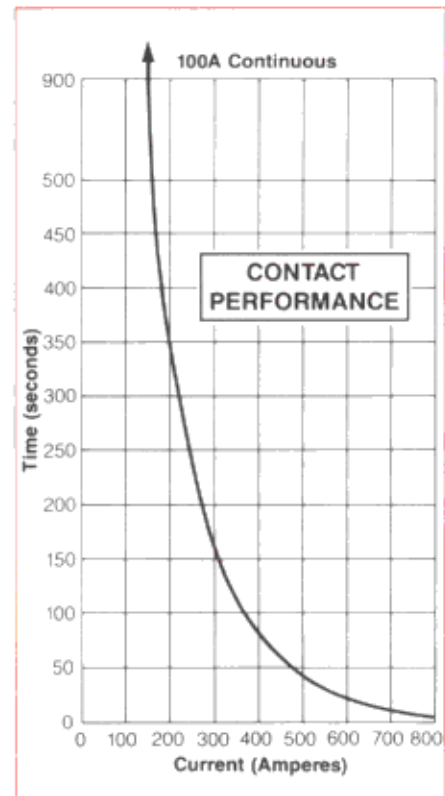

DC88E

Thermal current rating (100%): 80 Amperes

Intermittent current rating:

| | |
|----------|-------------|
| 30% duty | 150 Amperes |
| 40% duty | 130 Amperes |
| 50% duty | 120 Amperes |
| 60% duty | 105 Amperes |
| 70% duty | 95 Amperes |

Typical fault currents which can be ruptured (5ms time constant):

DC88E* 800 Amperes at 48V D.C.

DC88BE* 600 Amperes at 80V D.C.

* Normally open contacts, not normally closed contacts.

Maximum recommended contact voltages:

| | |
|--------|----------|
| DC88E | 48V D.C. |
| DC88BE | 96V D.C. |

Typical voltage drop across contacts per 100 Amperes:

| | |
|--------------------------|------|
| Normally open contacts | 40mV |
| Normally closed contacts | 50mV |

Mechanical life: $> 5 \times 10^6$

Coil power dissipation: 10-15 Watts

Maximum pull-in voltage (coil at 20°C):

60%V

Typical drop-out voltage: 10-25%V

Pull-in time (n/o contacts to close): 20ms

Drop-out time (n/o contacts to open):

| | |
|--|--------|
| Without suppression | 5ms |
| With diode suppression | 50ms |
| With diode and resistor (depending on value) | 8-20ms |

Main contact changeover time:

| | |
|----------------------------------|-----|
| Normally closed to normally open | 7ms |
| Normally open to normally closed | 4ms |

Typical contact bounce period: 3ms

Auxiliary contact thermal current rating:

5 Amperes

Auxiliary contact switching capacities

(resistive load):

| |
|-------------------|
| 5A at 24V D.C. |
| 2A at 48V D.C. |
| 0.5A at 240V D.C. |

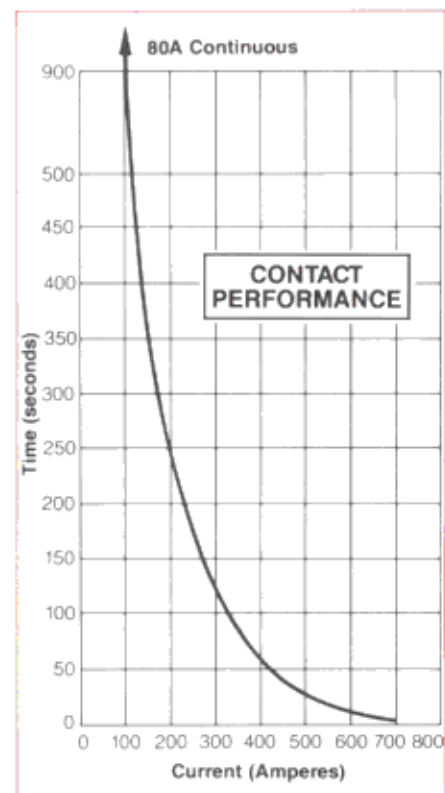

All the above figures should be used as a guide only.
Alternative ratings may be considered according to applications.

SW80

Single Pole Single Throw (On/Off) Contactor

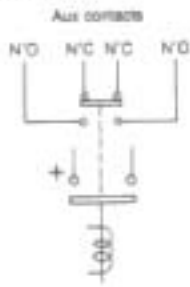

SW84

Single Pole Double Throw (Changeover) Contactor



SW85

Single Pole Single Throw (Off/On) Normally Closed Contactor

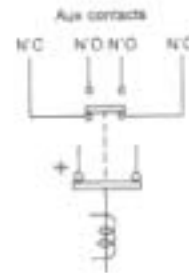

SW88

Paired Single Pole Double Throw Contactor for motor reversing

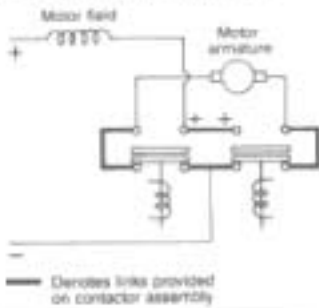

SW822

Paired Double Pole Single Throw Contactor for motor reversing

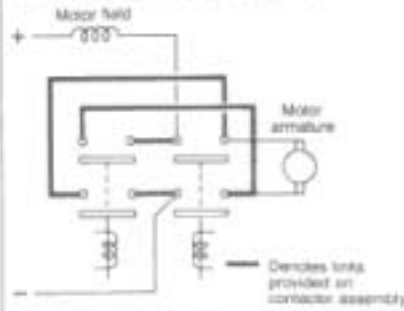

SW82

Double Pole Single Throw Contactor

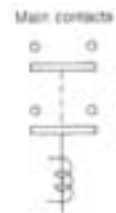

DC88 & DC88E

Monoblock Single Pole Double Throw Contactor for motor reversing

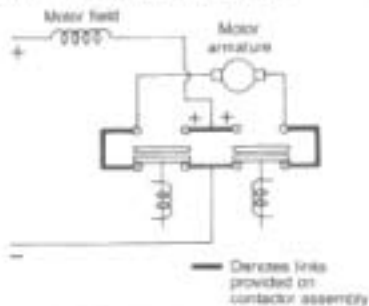

DC92 & DC92E

Monoblock 2 x SW80

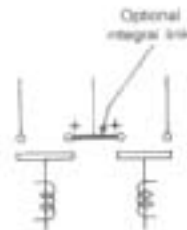

DC88P

Monoblock Single Pole Double Throw Contactor for motor reversing

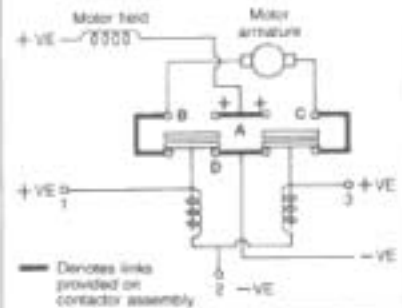

DC92P

Monoblock 2 x SW80

