



SW60P, SU60P & SW80P

Main Power Relays

For Heavy Duty D.C. Construction,
Forestry and Agricultural Vehicles



These Main Power Relays (sometimes called Ignition Relays) are eminently suitable for controlling the electrical services on heavy duty Construction, Forestry and Agricultural vehicles and machines. Designed to energise or isolate the vehicle lights, electrical pumps, fans, heating elements, solenoid valves etc by means of the key switch, they can take the place of several Cube relays, thus saving cost, space and installation time.

A range of coil voltages are available including continuously rated voltages for vehicle charging systems.

Three versions are offered here:

SW60P for continuous currents up to 80 Amperes.

SU60P for continuous currents up to 100 Amperes.

SW80P for continuous currents up to 125 Amperes.

Higher rated relays are also available.

The relays are enclosed in IP66 rated cases and can be mounted either directly to a panel (M4 tapped holes being provided) or by means of standard brackets (please see drawings below).



Dim	SW60P	SU60P	SW80P
A	86.4 (3.40)	90.3 (3.56)	93.3 (3.67)
B	74.0 (2.91)	77.0 (3.03)	80.5 (3.17)
C	48.7 (1.92) CRS	48.7 (1.92) CRS	Bracket cannot be fitted to base of coil
D	44.3 (1.74)	47.3 (1.86)	52.2 (2.06)
E	23.7 (0.93)	23.7 (0.93)	28.3 (1.11)
F	5.2 (0.20) Slots	5.2 (0.20) Slots	5.2 (0.20) Dia. Holes
G	34.4 (1.36)	35.0 (1.38)	45.0 (1.77)
H	42.0 (1.65)	45.0 (1.77)	54.0 (2.13)
J	48.7 (1.92) CRS	48.7 (1.92) CRS	44.5 (1.75) CRS
K	M6 Terminals	M8 Terminals	
L	6.3 (0.25) Spade Terminals for Coil Connections.		
M	21.0 (0.83) CRS	22.5 (0.88) CRS	28.6 (1.13) CRS

Table Dimensions in "mm (inches)".

For alternative mounting brackets, refer to main catalogue leaflets.

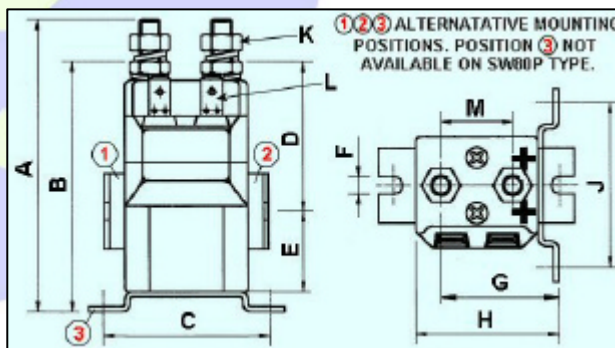

SW80P

Performance Data.

Contactor Type:	SW60P	SU60P	SW80P
Thermal Current (100%):	80 Ampere	100 Ampere	125 Ampere
Maximum DC Voltages which may be switched:	60 Volts DC		
Mechanical Life:	>3 x 10 ⁶ Cycles		
Maximum Coil Power (100%):	7 Watts	13 Watts	
Typical coil pick up voltage [at 20 C]:	50 - 66% of rated voltage.		
Typical coil drop out voltage [at 20 C]:	10 - 25% of rated voltage.		
Shock and vibration tested to:	BS EN 61373:1999 & IEC		

Please Note: All the performance data given here should be used as a guide only. Some derating or variation from the above figures may be necessary according to type and application.



Global Industrial Products, Inc.

3338 West Lake Ave.
Glenview, IL 60025 USA
Tel: 800-951-8774
Fax: 847-901-4036

Web Site: www.globalepower.com

