

# SOLID STATE DIGITAL METER MODULES

## 700 SERIES

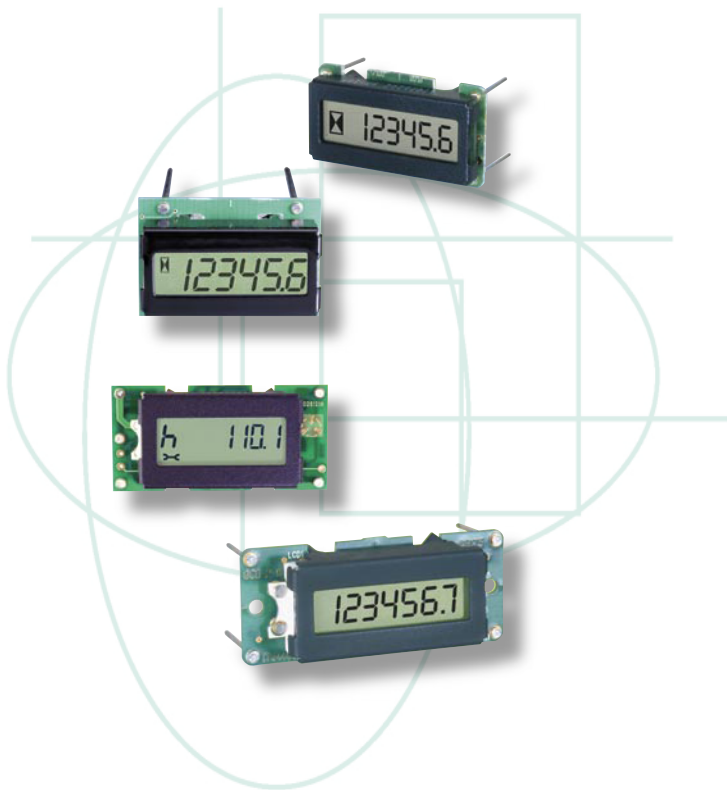

### DESCRIPTION

Solid-State Module Assemblies are designed for OEM applications. Global offers a wide selection of miniature AC & DC meter assembly modules for PC board mounting applications.

700 – 703: Single-function 6-digit display for Counter or Hour Meter configurations.

708 & 721: Dual channel, 6 & 7-digit display for Maintenance/Hour Meter or Trip Odometer configurations.

720: Single channel 7-digit Odometer configuration.

### APPLICATIONS

These models offer a variety of functions, sizes, voltages and customizable options to fit most applications. Ideal for OEMs, contract manufacturers, and panel makers for monitoring equipment usage, scheduling maintenance, warranty validation, rental/leasing use and more. Used extensively in industrial, agricultural, military & specialty vehicles, as well as applications such as: vending machines, medical & office equipment, fuel pumps, and consumer products.

### FEATURES

- Selection - hour meters, counters, odometers, maintenance monitors and more.
- Solid State Circuitry - no moving parts to wear out. Silent operation and years of rugged & reliable operation.
- Precision - faster response, more precise and easier to read than electromechanical meters.
- Crisp, clean readouts - high-contrast 5 & 7mm LCD displays.
- Versatility - compact module designs with high quality components to minimize space.
- AC/DC Configurations - wide range of operating voltages & noise protection.
- OEM Compatibility - an unparalleled selection of power compatibility, design configurations and functionality for OEM custom designs, panel makers and contract manufacturers.
- Distinctive Icons - clear indicators for hour meter/timer activation and display modes.
- Backlighting - available on all models (see model coding chart or consult factory).
- Power-up LCD Function Test - displays all 8's for 1 sec at power-up (models 700-703 only).
- EEPROM memory – nonvolatile, retention of data for as much as 25 yrs.+ without power.
- Manufactured under ISO 9001 Certified Quality Management System

GLOBAL INDUSTRIAL PRODUCTS

3338 WEST LAKE AVENUE

GLENVIEW, IL 60026 USA

TEL (847) 901-4040

FAX (847)901-4036

[www.globalepower.com](http://www.globalepower.com)

## MODEL CODING ASSEMBLY MODULES 700, 701, 703

700	P	N	-	0	0	0
Model Number	Digit Height	Reset Control Options	Functions	Voltage	Reset/Backlight Configurations <sup>(1)</sup>	
700 (6-digit) Hour Meter	P - 5mm digits	R - Wired Reset N - No Reset	0 - AC/DC (700 only)	0 - 5-12 VDC nom (4.75-15 abs) 6-12 VAC nom (5-15 abs)	0 - No Reset, No Backlight 2 - Reset, No Backlight	
701 (6-digit) Hour Meter	P7 <sup>(2)</sup> - 7mm digits		1 - DC only with wired Enable for Hour/Count (701&703 only)	1 - 12-48 VDC nom (9-60 abs) 20-60 VAC nom (15-75 abs)	H - Reset, Internal Backlight <sup>(3)</sup> J - No Reset, Internal Backlight <sup>(3)</sup>	
703 (6-digit) Pulse Counter			2 - AC/DC with wired Enable (701&703 only)	2 - 48-150 VDC nom (36-185 abs) 100-230 VAC nom (75-287 abs)	4 - Reset, External Backlight 5 - No Reset, External Backlight	
				4 - 12 VDC only (9-15 abs) Backlight Options "H" & "J" only.		

NOTE: (1) All Backlight configurations - require 12 VDC (only) connection to illumination pin.

(2) 7mm models - Backlighting only available as External.

(3) Available only in 5mm & with voltage option 4 only.

## MODEL CODING ASSEMBLY MODULES 708, 720, 721

708	P	R	- x x x x
Model Number (& function)	Digit Height	Reset Control Options	Sequential Specification
708 (6-digit) Dual Channel Maintenance/Hour Meter	All Models P - 5mm digits	Model 708/721 R - Wired Reset for Maintenance or Trip Display	Consult Global for: display format, voltages, connection terminology, backlighting, pre-scaling and programming options.
720 (7-digit) Single Channel Odometer		Model 720 R - Wired Reset	
721 (7-digit) Dual Channel Odometer/Trip Odometer			

## MODULE ASSEMBLY SPECIFICATIONS

<b>Display</b>	6-digit, 5 or 7 mm high	(Models 700, 701, 703)
	Dual-Channel 6-digit, 5 mm high	(Model 708)
	7-digit, 5 mm high	Model 720
	Dual-Channel 7-digit, 5 mm high	(Model 721)
<b>Range &amp; Resolution</b>	Hour Meters 99,999.9 hrs.	(Models 700, 701, 708)
	Maintenance 3,999.9 hrs.	(Model 708/2nd Channel)
	Counters 999,999 counts	(Model 703)
	Odometers 999,999.9 increments	(Models 720, 721)
	9,999,999	(Model 720) optional resolution
Trip 999.9	(Model 721/2nd Channel)	
<b>Accuracy</b>	Hour Meters $\pm 0.1\%$	(Models 700, 701, 708)
	Counters $\pm 1$ count	(Model 703)
	Odometers $\pm 1$ increment	(Model 720, 721)
<b>Humidity</b>	95% Non-condensing at 38°C	
<b>Operating Temperature</b>	-40°C to + 85°C	
<b>Storage Temperature</b>	-50°C to + 85°C	
<b>Operating Frequency (AC units)</b>	48 to 440 Hz abs.	
<b>Memory</b>	Main power must be applied for 5 sec to activate memory (with no loss of time/counts). EEPROM-Data retention 25+ years without power present.	
<b>Input Signal (DC Only)</b>	Counter	Model 703 - 500 Hz max, 50% duty cycle (1ms low, min, between consecutive highs).
	Maintenance Monitor	Models 701, 708 - Power must be applied for 0.5 sec, min, to accumulate time.
	Odometer	Model 720 - Varies depending on model configuration (consult factory).
	Trip/Odometer	Model 721 - 500 Hz max, 50% duty cycle (1ms low, min, between consecutive highs).
<b>Input Signal (AC/DC)</b>	Hour Meter	Models 701, 708 - Power must be applied for 0.5 sec, min, to accumulate time.
	Counter	Model 703 - 1 Hz max, 50% duty cycle (500ms low, min, between consecutive highs).
<b>Reset</b>	All Models	Main power must be applied for a minimum of 0.5 sec. prior to reset signal.
	Models 700, 701, 703	6ms, min, at operating voltage.
	Model 708	Maintenance 2 or 4 sec, factory programmed; hour meter not resettable.
	Model 720	70ms min at operating voltage.
	Model 721	Trip channel 2 or 4 sec, factory programmed; odometer is not resettable.
		Note: Max Reset frequency is 150Hz for AC models.
<b>Notes:</b>	<ol style="list-style-type: none"> <li>All modules are supplied with critical components exposed. If the module is being used in an environment other than specified, the user must take precautions to package the module to provide adequate protection.</li> <li>For proper mechanical support, all module pins should be soldered to the PC-board.</li> <li>To prevent heat damage to components, module face should be 10-20mm minimum away from PC-board when flow soldered.</li> </ol>	

# 700 SERIES

## CURRENT CONSUMPTION: (MA MAX)

	Operating Voltage at Power Terminals	700, 701, 703 (5mm)	700, 701, 703 (7mm)	708, 721 (5mm)
External or Non - Backlight Models	5 - 12 VDC (@ 5 V)	0.5	0.5	N/A
	12 - 48 VDC (@ 12 V)	0.8	0.8	1.0
	48 - 150 VDC (@ 48 V)	0.8	0.8	N/A
	100 - 230 VAC (@ 120 V)	1.0	1.0	N/A
	100 - 230 VAC (@ 230 V)	2.0	2.0	N/A
Internal Backlight Models	12 VDC (only)	35	N/A	N/A
<b>At Illumination Pin</b>				
External Backlight Models	9-15 VDC (@12 V)	30	35	35

## MODULE DIMENSIONS: MM

### MODELS 700, 701, 703 - 5MM DIGITS



#### Non-Backlight

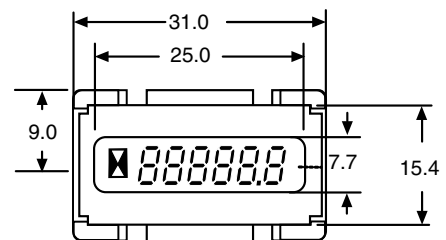
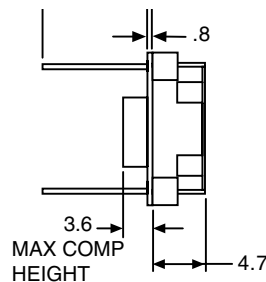
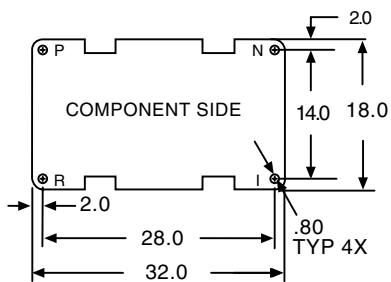

#### Backlight

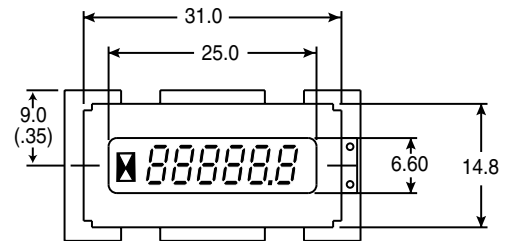
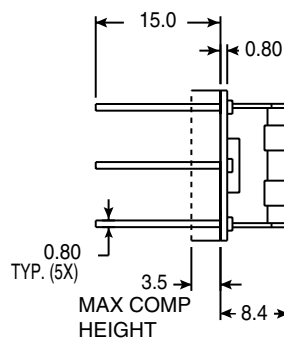
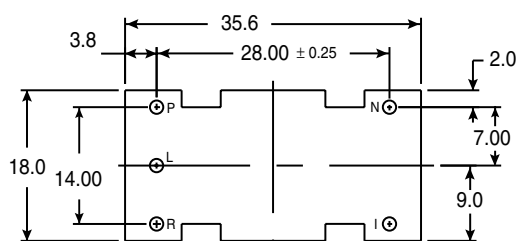

Note: Standard pin lengths are shown. Optional lengths are available.

# 700 SERIES

## MODULE DIMENSIONS: MM

### MODELS 700, 701, 703 - 7MM DIGITS

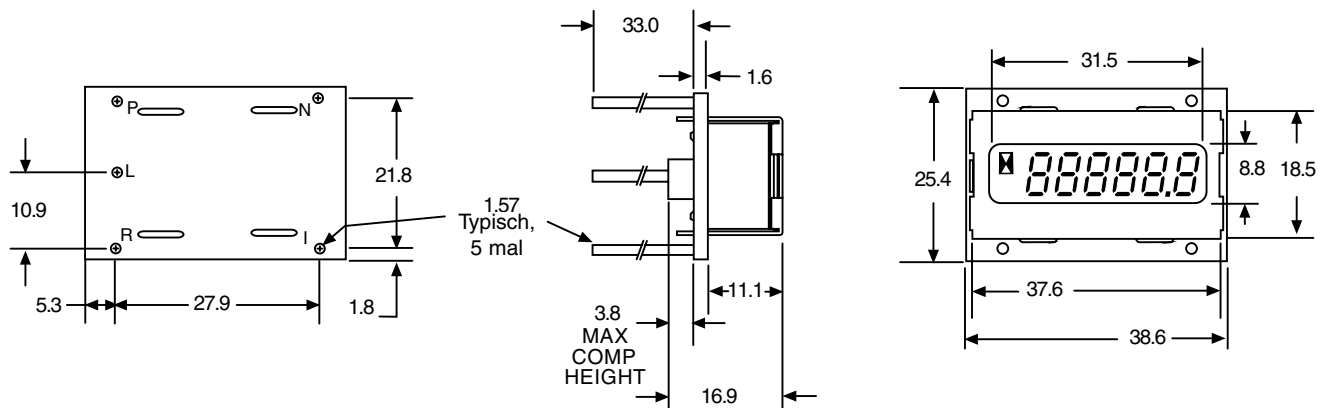

### MODEL 708

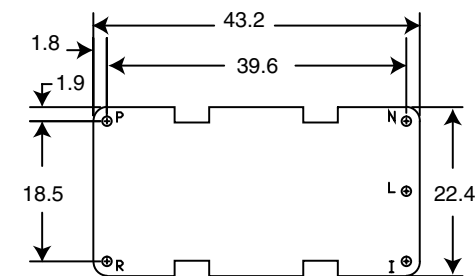

### MODEL 721

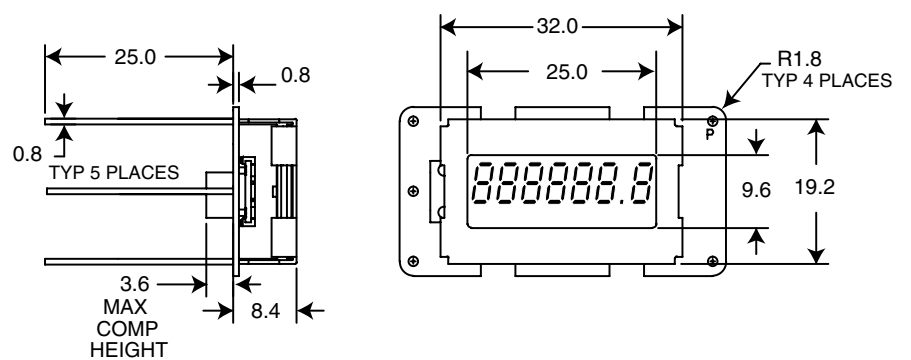

Note: Standard pin lengths are shown. Optional lengths are available.

