

# MOSFET ELECTRONIC MOTOR SPEED CONTROLLERS

MODELS 1204X/1205X

1960 · 2000



## DESCRIPTION

*Curtis PMC Models 1204X/1205X are power MOSFET electronic motor speed controllers designed to provide smooth, silent, efficient and cost effective speed, torque and braking control.*

## WARRANTY

One year from date of delivery.

## Specifications:

- Frequency of Operation: 15 kHz
- Standby Current: less than 20 mA
- Standard Throttle Input: 0-5k ohms  $\pm$ 10% (others available)
- Weight: 1204: 1.8 kg (4 lbs); 1205: 2.7 kg (6 lbs)
- Full Power Operating Temperature Range: -25°C to 75°C (controller temperature)

# CURTIS

## Application

Curtis PMC MOSFET motor speed controllers are ideal for a variety of electric vehicle applications, including industrial trucks, personnel carriers, material handling vehicles, tow tractors, walkie and small forklift applications, scrubbers, sweepers, scissors-lift and boom trucks, etc.

## Features:

- High frequency switching and ultra low voltage drops provide very high efficiency and silent operation. Costs, heatsinking requirements and motor and battery losses are reduced. Low end torque, range and battery life are increased.
- Environmental protection provided by a rugged, sealed (factory serviceable) anodized aluminum extrusion housing. Simple mounting and wiring with push-on type connectors for control signals. Plated solid copper busses used for all power connections.
- Thermal protection and compensation circuit provides under-temperature cutback, constant current limit over operating range, and linear rollback in over-temperature. No sudden loss of power under any thermal conditions.
- High pedal disable option prevents controller operation if the key switch is turned on while throttle is applied.
- Static return to off option prevents controller operation if the keyswitch is turned on while a forward or reverse direction is selected.
- Adjustable acceleration rate, current limit (protected against exceeding controller rating) and plugging current limit. Adjustments are accessed through sealed screws in side of housing (optional). No adjustments are required.
- Variable plugging current feature provides throttle position control over braking to improve driveability.
- Full fault detect circuitry monitors power supply, throttle connections, output transistors, bypass contactor, etc., to prevent runaway.
- Delayed bypass (1A) output drives optional bypass contactor (normally not required) after throttle reaches 90% and bypass delay times out (available on 12 and 24-36 volt models only).
- Arcless contactor switching for F/R contacts and bypass contacts (if opened below controller current limit).
- Short circuit protected F/R and bypass contactor drivers to prevent failure of sealed unit in the event of an accidental short in contactor coil circuit.

CURTIS PMC MODELS	VOLTAGE INPUT (volts)	CURRENT LIMIT (amps)	2 MIN RATING (amps)	5 MIN RATING (amps)	1 HOUR RATING (amps)	VOLTAGE DROP @ 100A	UNDERVOLT CUTBACK (volts)
1204X -12xx	12	275	275	200	125	.35V	9
-14xx	12	400*	300	210	135	.25V	9
-42xx	24-36	275	275	200	125	.35V	16
-44xx	24-36	400*	300	210	135	.25V	16
-52xx	36-48	275	275	200	125	.35V	21
1205X -14xx	12	400	400	275	175	.25V	9
-16xx	12	500*	425	285	185	.20V	9
-44xx	24-36	400	400	275	175	.25V	16
-46xx	24-36	500*	425	285	185	.20V	16
-53xx	36-48	350	350	250	150	.35V	21

\* 30 second rating

### Dimensions: mm (inches)

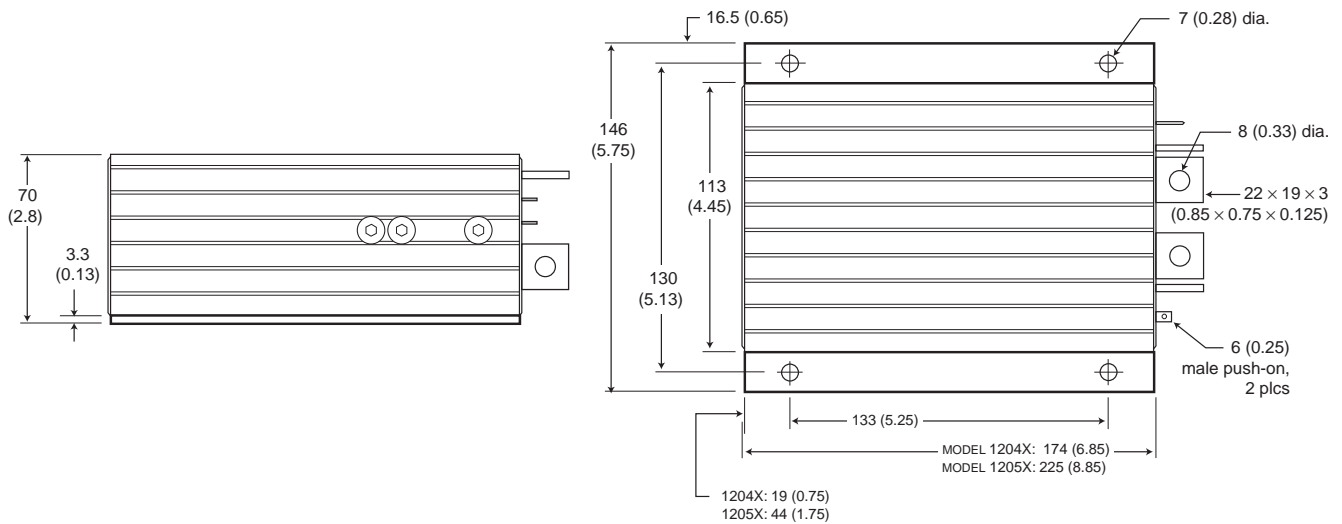

### Typical Wiring Diagram:

