

# MICROPROCESSOR MOTOR SPEED CONTROLLERS

MODELS 1214/1215/1219

1960 • 2000

# CURTIS



## DESCRIPTION

*Curtis PMC 1214/1215/1219 series of motor speed controllers feature a microprocessor based logic section combined with a proven MOSFET power section. The 1214/1215/1219 series controllers are efficient, cost effective and easy to install.*

## WARRANTY

One year from date of delivery.

### Application

The Curtis PMC 1214/1215/1219 controllers are ideally suited for larger electric vehicle applications, such as walkie/rider pallet trucks, personnel carriers, stackers, reach trucks, fork lifts and other series or compound motor applications.

### Features

- Compact size.
- Environmental protection provided by a sealed package.

### Features, continued

- Advanced high frequency power section utilizing custom power MOSFETs provides high efficiency, silent operation and reduced motor and battery losses.
- Power connections made by solid copper busses with polarized Molex connector for control signals.
- Thermal protection and compensation circuitry provide under temperature cutback, constant current limit over the operating range and linear rollback in over temperature. No sudden loss of power under any thermal conditions.
- Over voltage and under voltage protection.
- Programmable through the Curtis PMC 1307 handheld programmer, an optional universal unit which allows programming, testing, and diagnostics.
- Complete diagnostics of the controller can also be accomplished with the built-in status LED.
- Meets or exceeds EEC fault detection requirements with circuitry and software to detect faults in the throttle circuit, MOSFET drive circuits, MOSFET transistors, contactor drivers and contactors.
- Input sequencing options include neutral start (HPD) and static return to off (SRO).
- True arcless contactor switching with microprocessor controlled contactor sequencing.
- Throttle position variable or fixed plugging current options.
- Neutral braking option provides for automatic plug braking in neutral.
- MultiMode™ option for programmable two mode (current limit, speed, acceleration) operation.
- Emergency reverse function (belly button) provides full function with a single input. Additional output provides for an emergency reverse circuit continuity check.
- Anti-rollback (ramp start) function gives full power for starting on ramps.
- Simple contactor and switch wiring. Coil drivers are monitored for short and open circuit for fail-safe operation.
- Flexible throttle circuitry accepts a variety of throttle types including: 5k-0, 0-5k, 0-5v, 0-10v and three wire potentiometer.

## Specifications

CURTIS PMC MODELS	VOLTAGE (volts)	CURRENT (amps)	2 MIN RATING (amps)	TYP. VOLTAGE DROP @ 100A (volts)	UNDERVOLTAGE CUTBACK (volts)
1214-8XXX	24-36	400	400	<0.20	16
1214-8XXX	36-48	350	350	<0.30	21
1215-8XXX	24-36	500	500	<0.16	16
1215-8XXX	36-48	500	500	<0.20	21
1219-8XXX	24-36	600	600	<0.12	16
1219-8XXX	36-48	600	600	<0.15	21

## Dimensions: mm (inches)

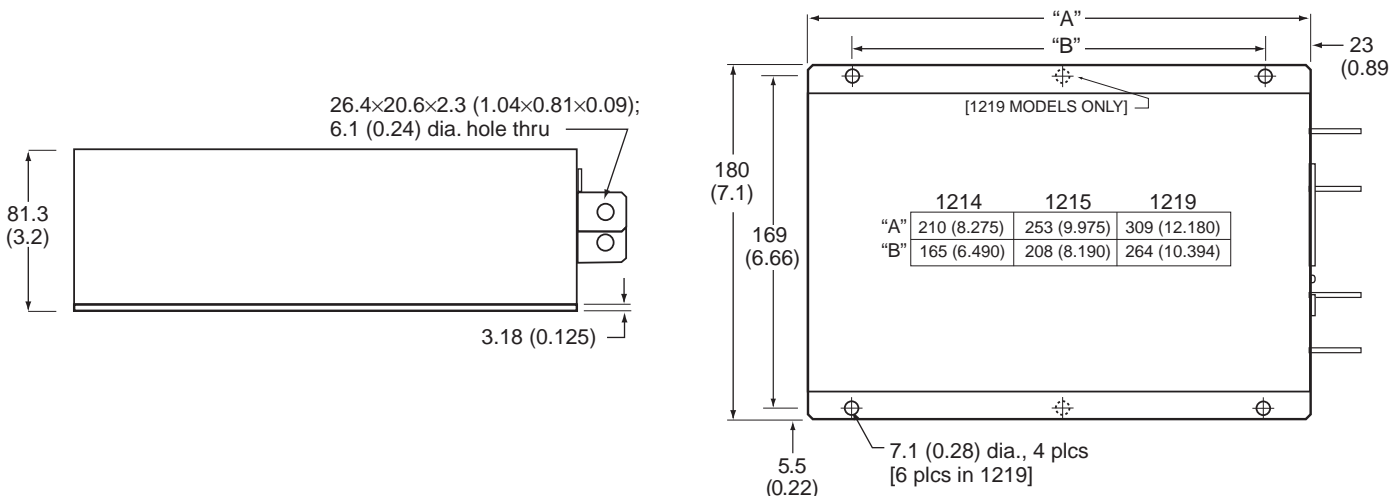

## Typical Wiring Diagram

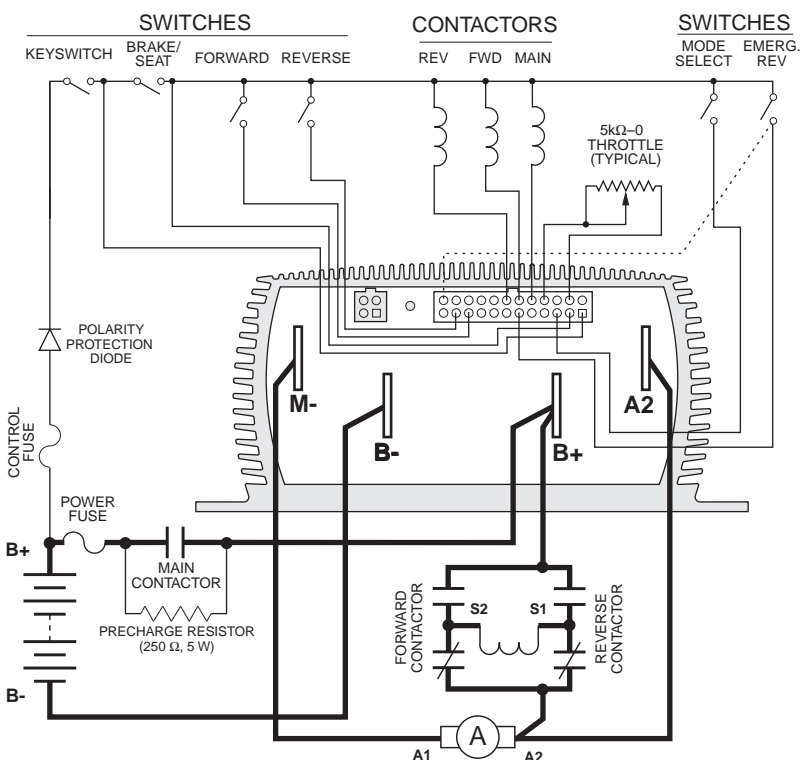

### 24-pin detail

