

# ON ROAD MOTOR SPEED CONTROLLERS

MODEL 1231C ■ MODEL 1221C

# CURTIS



## DESCRIPTION

*The Curtis PMC models 1231C and 1221C motor speed controllers provide smooth, silent, efficient and cost effective speed control for on-road electric vehicle applications.*

*These controllers utilize power MOSFET technology, pioneered by Curtis PMC, to provide benefits unavailable with older speed control systems.*

## WARRANTY

One year from date of delivery, subject to conditions of warranty.

## Application

The Curtis PMC models 1231C and 1221C are high power, heavy duty MOSFET electronic motor speed controllers which are ideal for use in electric commuter vehicles, light delivery trucks, and other vehicles utilizing up to 144 volts.

## Specifications

- Frequency of Operation: 15/1.5 kHz
- Standby Current: less than 30 mA
- Ambient Operating Temperature Range: -25°C to 50°C
- Controller Temperature Cutback Point: -25°C and +85°C

## Features

- High frequency switching and ultra low voltage drop provides very high efficiency and quiet operation. Costs, heatsinking requirements and motor and battery losses are reduced. Low end torque, range and battery life are increased.
- Environmental protection provided by a sealed (factory serviceable), rugged, anodized aluminum extrusion housing. Simple mounting and wiring with push-on type connectors for control signals. Plated solid copper busses used for all power connections.
- Thermal protection and compensation circuit provides under-temperature cutback, constant current limit over operating range, and linear rollback in over-temperature. No sudden loss of power under any thermal conditions.
- Frequency shifting from 15 kHz to 1.5 kHz at low throttle settings provides improved protection against stalled motors.
- Heavy duty power base in 1231C contains additional active devices to improve power handling capability.
- Potentiometer fault protection circuitry disables the controller if the throttle wires become open.
- High Pedal Disable prevents controller operation if the key switch is turned on while throttle is applied.
- Optional heatsink (p/n 16286) for model 1231C controller improves thermal capability.
- No adjustments are required.
- Simple installation — Uses a two wire throttle potentiometer.

CURTIS PMC MODELS	VOLTAGE (volts)	CURRENT (amps)	2 MIN RATING (amps)	5 MIN RATING (amps)	1 HOUR RATING (amps)	VOLTAGE DROP @ 100A	UNDERVOLT CUTBACK (volts)
1231C-86XX	96-144	500	500	375	225	.30	64
1231C-77XX	72-120	550	550	375	225	.30	43
1221C-74XX	72-120	400	400	250	150	.50	43

**1231C Dimensions: mm (inches)**

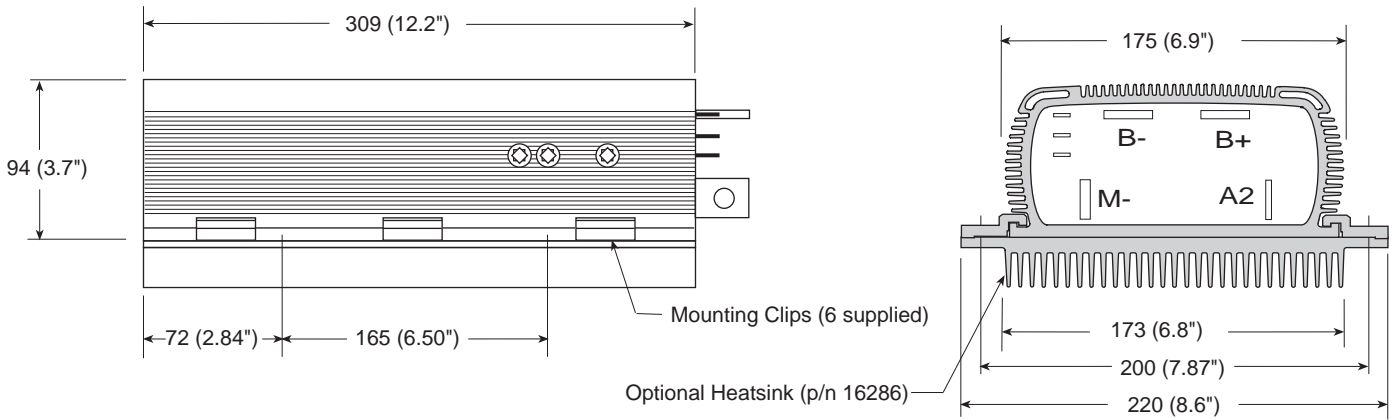

**1221C Dimensions: mm (inches)**

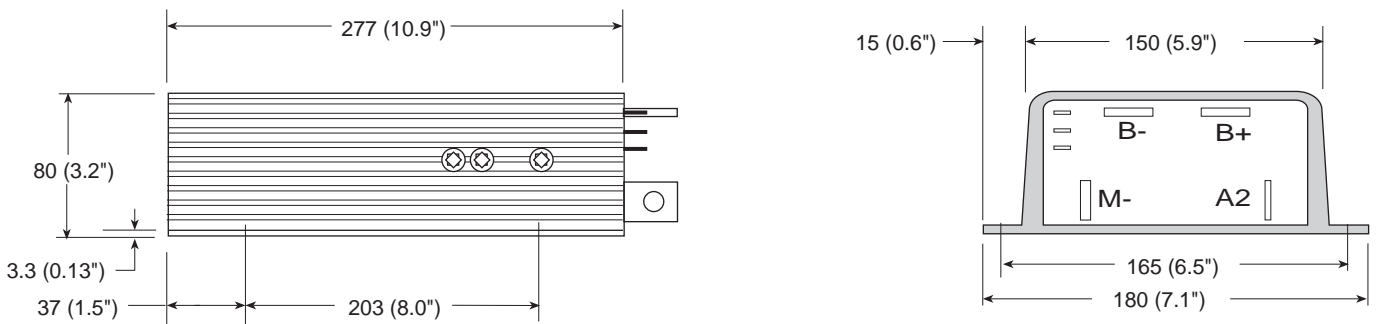

**Typical Wiring Diagram:**

