

SEPARATELY EXCITED ELECTRONIC MOTOR SPEED CONTROLLER

MODEL 1242 SepEx®



DESCRIPTION

Curtis PMC Model 1242 SepEx® programmable controllers provide smooth and seamless control of separately excited motors. An advanced MOSFET power section provides very high efficiency, silent operation and reduced motor and battery losses.

WARRANTY

Two Year Limited Warranty
(see terms of sale for specifics)

Application

Curtis PMC SepEx® controllers are designed for small material handling and other light industrial vehicles using separately excited motors. These include, low lifts, stackers, personnel carriers and other industrial vehicles.

CURTIS

Features

- Full bridge control of the motor field allows reversing without the use of direction contactors.
- Fully compatible with all Curtis handheld and PC based programmers for testing, diagnostics and parameter adjustments.
- Armature current controlled at all times, reducing arcing and brush wear.
- Neutral braking provides automatic braking in neutral, simulating the feel of compression braking. Braking level is adjustable.
- MultiMode® allows four user selectable vehicle operating profiles.
- Programmable to match individual separately excited motor characteristics.
- Meets or exceeds EEC fault detect requirements with circuitry and software to detect faults in the throttle circuit, MOSFET drive circuits, and emergency reverse input wiring.
- Vehicle speed is controlled and limited at top end via motor field control.
- Linear temperature cutback on motor drive current limit. No sudden loss of power under any thermal conditions.
- Under voltage cutback reduces motor current to maintain the battery voltage above the under-voltage point.
- HPD and SRO interlock options ensure proper startup sequence.
- Emergency reverse (belly button) input causes immediate reversal upon activation.
- Integral fault detect LED flashes error code information.
- Two fault outputs provide diagnostic information to dash mounted displays.
- Fully protected inputs and outputs.
- Active power on self test and continuous diagnostics during operation.
- Internal watchdog circuits ensure proper software operation.

Meets US and International Regulations

UL Recognized component status (ULAU1841)
EN 12895

Model Chart

Curtis PMC Model	Voltage (volts)	Armature Rating (amps) 2 minutes	Plug Current (amps)	Field Rating (amps) 2 minutes
1242-42XX	24-36	200	300	25
1242-43XX	24-36	300	400	25
1242-44XX	24-36	400*	450	25

* 1 Minute

Typical Wiring Diagram

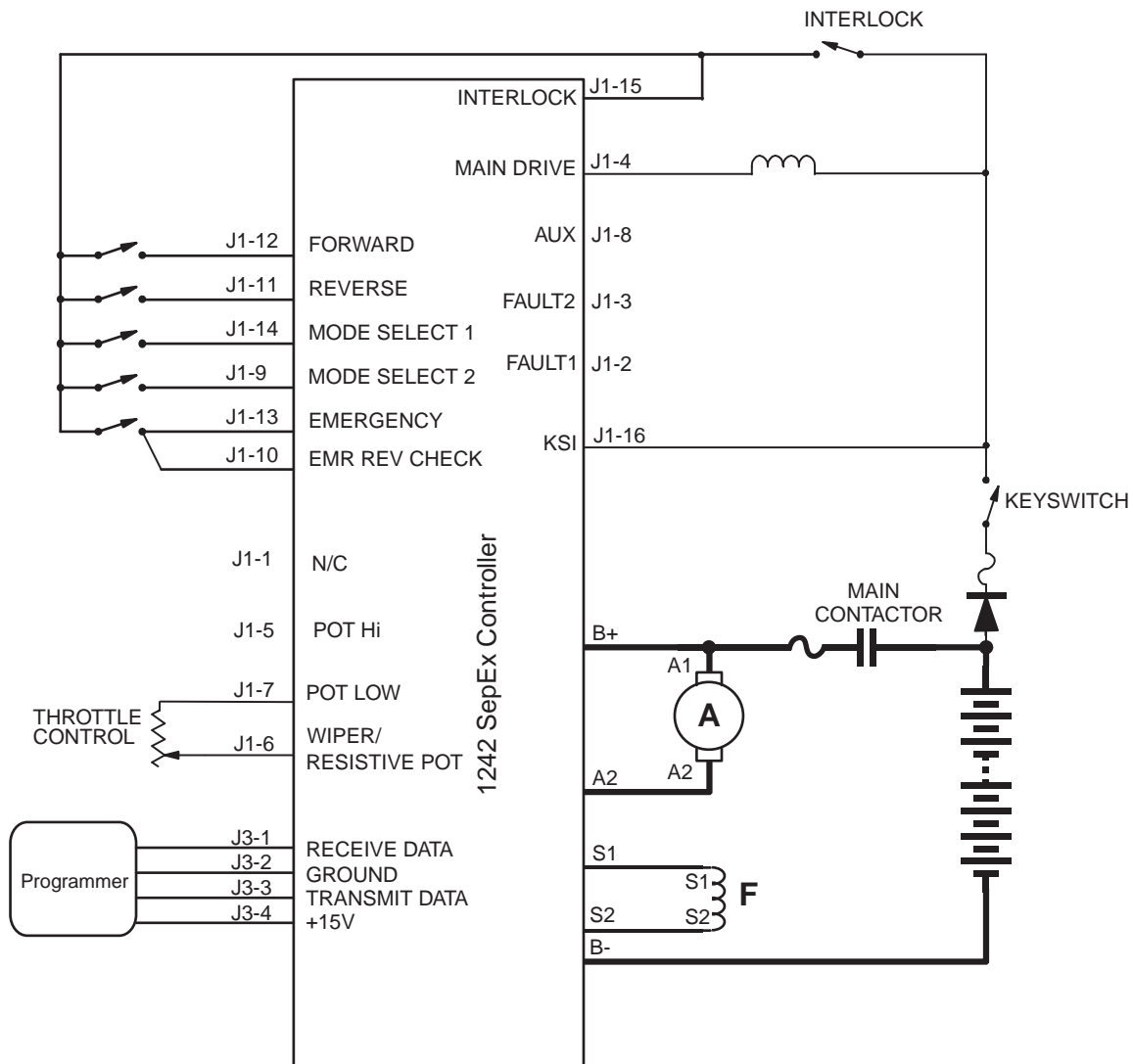

Models 1242 Dimensions: mm (inches)

