



**CURTIS**



**MODEL 1297**

**INTEGRATED TRACTION  
& HYDRAULIC SYSTEM  
CONTROLLER**

*Fully programmable, MultiMode™ controller.*

Distributed by GLOBAL INDUSTRIAL PRODUCTS 3338 West Lake Ave., Glenview \* IL \* (800) 951-8774  
TEL: 847-901-4040 FAX: 847-901-4036 EMAIL: SALES@GLOBALEPOWER.COM

[www.globalepower.com](http://www.globalepower.com)

# INTEGRATED TRACTION & HYDRAULIC SYSTEM CONTROLLER

MODEL 1297

# CURTIS



## DESCRIPTION

*Curtis Model 1297 Integrated System Controller combines traction and hydraulic motor control into a single compact unit. The controller provides smooth and seamless operation in the control of separately excited regenerative traction motors and precise control of hydraulic motors and valves.*

## WARRANTY

Two Year Limited Warranty  
(see terms of sale for specifics)

## Application

The Curtis Model 1297 Integrated System Controller is ideal for use with vehicles such as electric pallet movers, walkies, stackers, order pickers and other small industrial vehicles.

## Features

### Powerful and Reliable Controller

- Combines the proven reliability of a 150 to 350 amp SepEx<sup>®</sup> regenerative traction motor controller and a 200 to 300 amp series hydraulic pump motor control with variable Pulse-Width Modulation and ramp On/Off options in one integrated package.
- Additional drivers are included for proportional lowering valve, horn, main contactor, and electro-magnetic brake.
- Tiller and multifunction display wiring are linked through separate serial communication ports for harness reduction.

### Fully programmable

- Fully compatible with all Curtis handheld and PC based Programmers for testing, diagnostics and parameter adjustments.
- MultiMode™ feature allows for the selection of two user selectable operating profiles.

### Safety Features

- Active power-on self-test and continuous diagnostics during operation includes internal and external watchdog circuitry to assure safe, controlled motor operation.
- Protected against reverse battery connection.

### Meets US and International Regulations

The Curtis Model 1297 Controller is designed to meet:  
EN 50081/2/08.93 for EMC emissions  
EN 50082-2:1995 for EMC immunity  
IEC 801-2 level 4 for ESD to 15kV  
EN 1175-1:1998; VDE0117:1991; IEC 529 class IP53  
UL Material Listing for flammability class 94V-0

## Options

- Curtis Model 840 "Spyglass" LCD Multifunction Display contains 8 large, readable characters to provide display of battery discharge (BDI), hour meter and error messages. Backlit display is also available.
- Tiller Multiplexer  
Provides monitoring and control capability for up to 12 analog or digital signals from operator controls on tiller. Each signal is sampled every 20 milliseconds for fast response .



## Model Chart

Model No.	Voltage Rating (volts)	Boost 10 sec. (amps)	Drive 2 min. (amps)	Current Limit 1 Hour (amps)	Pump 2 min. (amps)	Current Limit 1 Hour (amps)	Field 2 min. (amps)	Current Limit 1 Hour (amps)
1297-22XX	24	180	150	75	200	80	25	15
1297-23XX	24	300	250	90	200	80	25	15
1297-24XX	24	420	350	120	300	100	35	18

## Connector Without MUX Controller

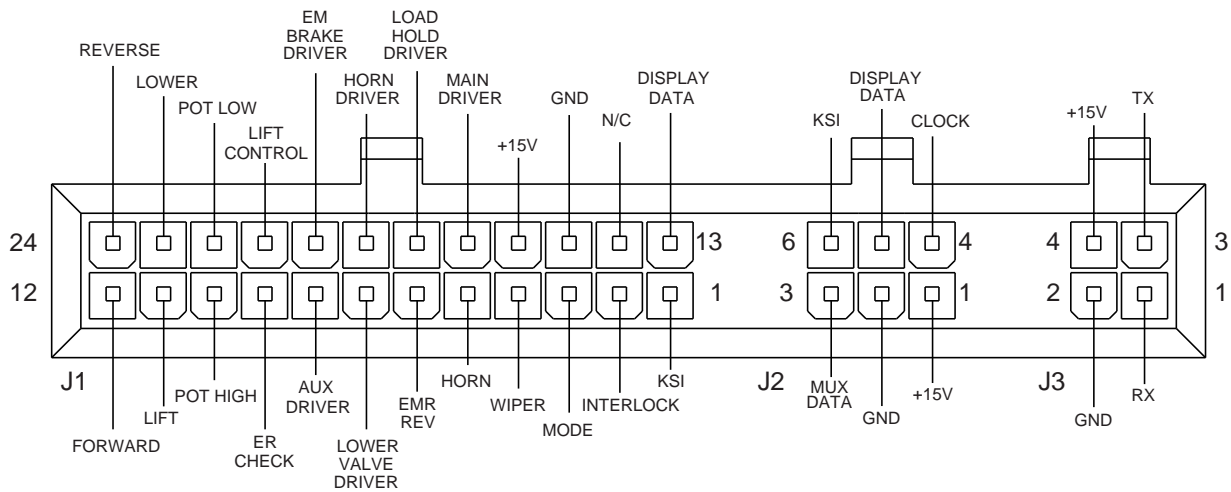

## Connector With MUX Controller

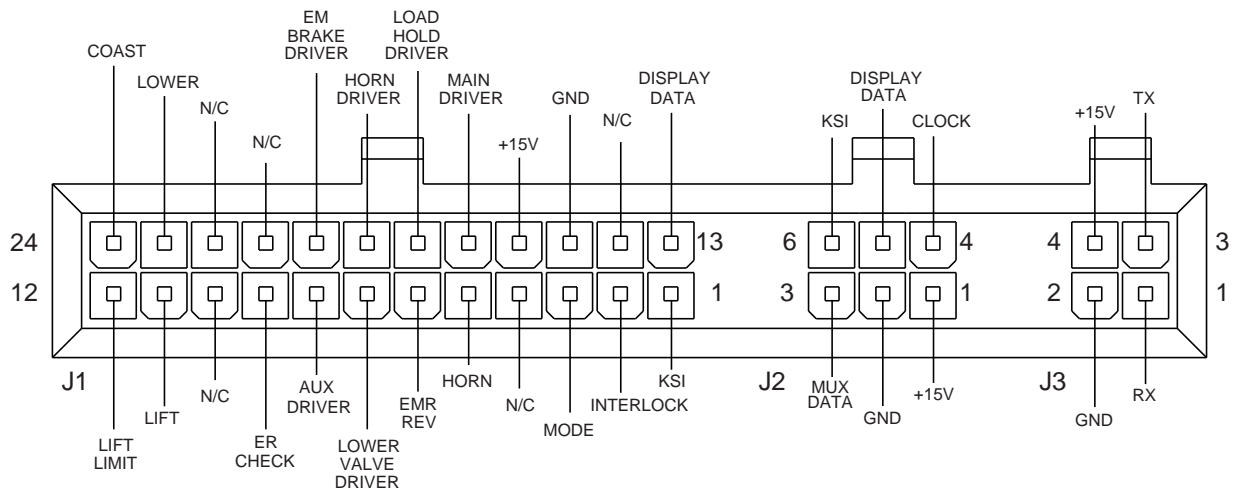

# Wiring Diagram With MUX Controller

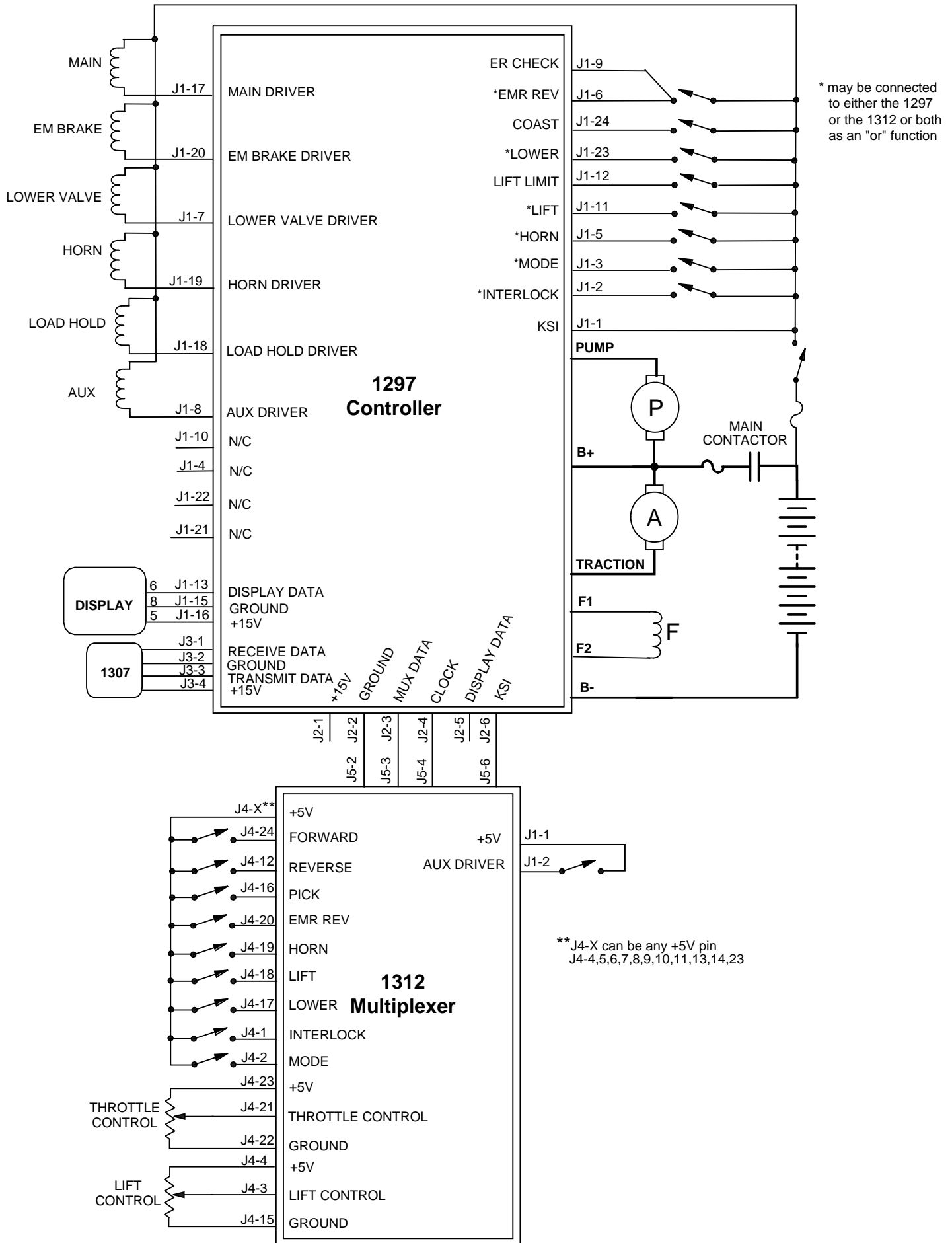

Wiring Diagram Without MUX Controller

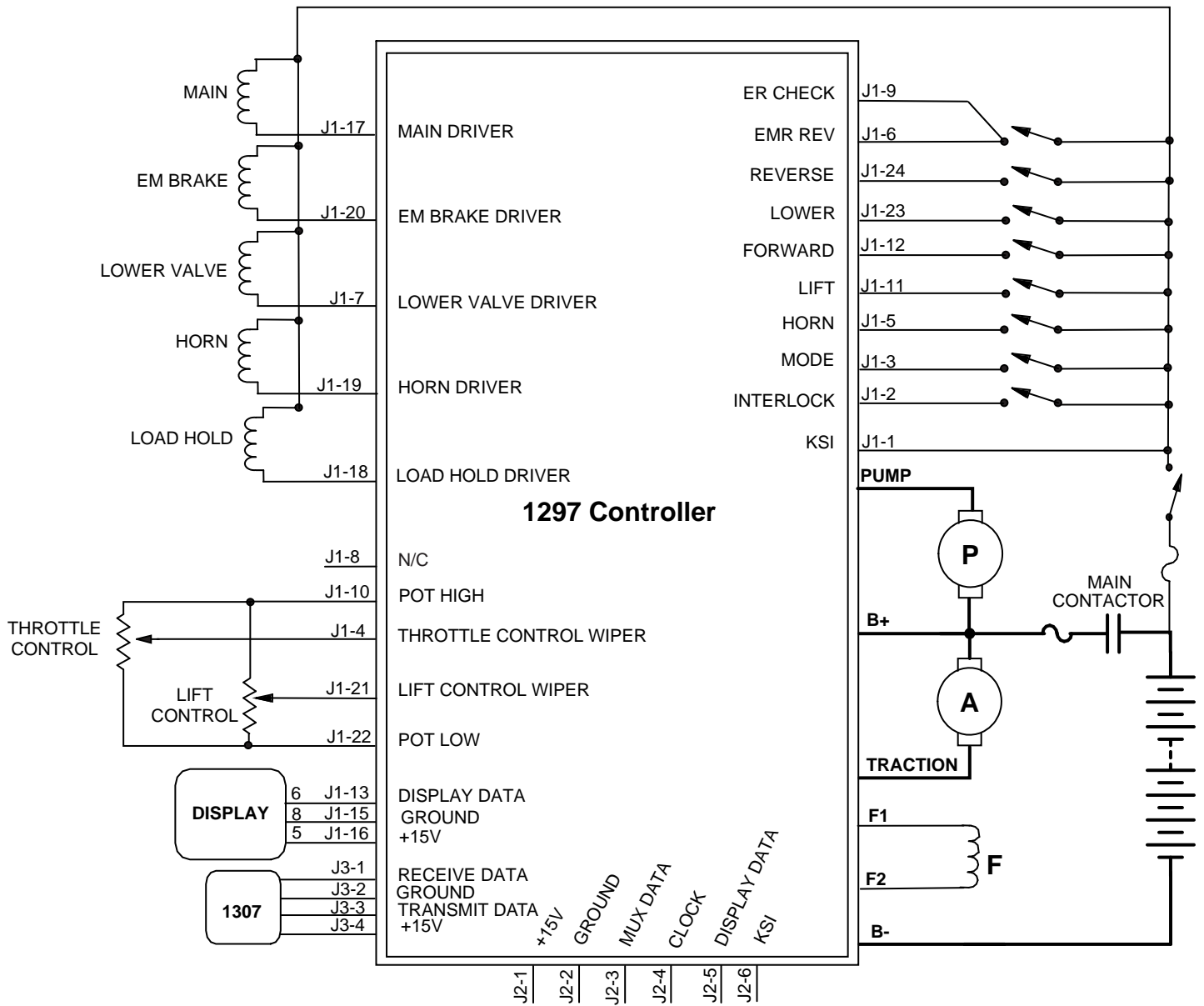

## Dimensions: mm (inches)

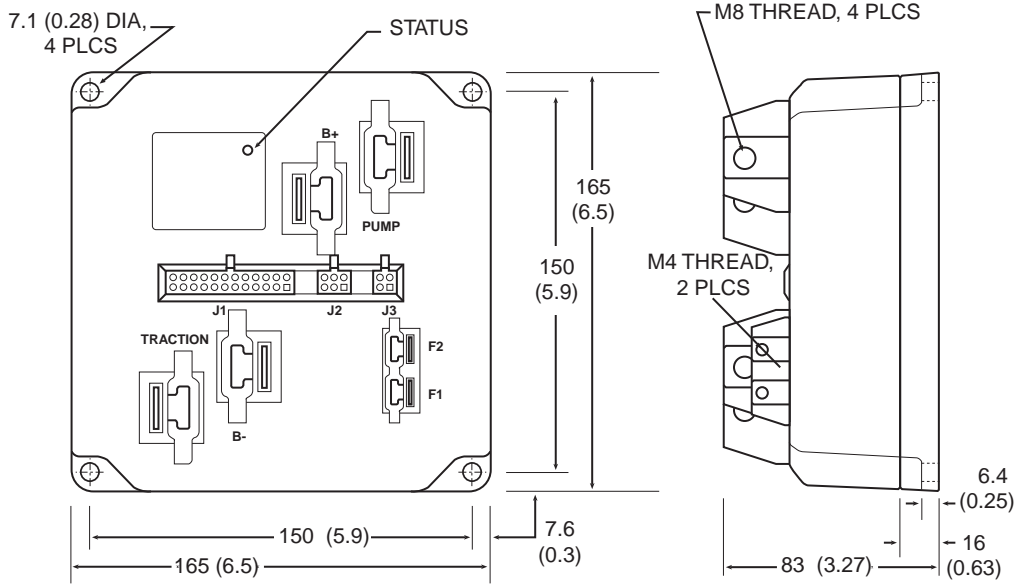

## Model 840 "Spyglass" Gage

The optional Curtis Model 840 "Spyglass" Gage is designed to provide a cost effective means of communicating the various system parameters from the Curtis PMC Model 1297 Motor Controller.

The basic Spyglass display contains an 8-character Alphanumeric LCD display along with 3 LED's (1 red, 1 yellow and 1 green). A 6 LED model is also available.

The LED's may flash to draw attention to system failures as well as indicate the safe operation of the system while being either steadily lit or extinguished.

The LCD display provides details of the system operation such as operating hours, battery charge condition, maintenance reminders and specifics pertaining to any faults encountered.

The Spyglass Gage is available in a 52 mm round case with a glass face, a rectangular DIN mounted Gage or uncased for custom installation. Connection is provided by an 8 pin Molex connector.

The Spyglass Gage is rated to the SAE J1378 standard for Shock and Vibration. It can withstand temperatures between -10C to 70C when used with the optional freezer accessory. The encased Gages (round and DIN) are rated to IP65 for the front seal and IP40 for the rear seal.

Backlit display is also available as an option.

