



3200 SERIES



DESCRIPTION

The Curtis enGage™ IV is a microprocessor based instrument panel that can be customized to monitor, display and control numerous vehicle functions in a single integrated package. The panel is fully compatible with CAN (Controller Area Network) Open and SAE J1939 protocols.

APPLICATION

Electric and engine powered industrial and commercial vehicles, including material handling, outdoor power and construction equipment, stationary equipment, commercial cleaning equipment, and light-on-road vehicles.

QUALITY COMPLIANCE

Manufactured under ISO 9001 certified Quality Management System. UL recognized & CE certified.

FEATURES

- Fully customizable instrument. You design your own instrument to your specific applications and needs, with a wide palette of possibilities.
- Analog, digital & CAN functionality in one instrument. All aspects of vehicle management, control and display can be accommodated.
- CAN communication allows seamless interconnectivity with other system components, such as motor controllers.
- SAE J1939 compatibility allows monitoring of a variety of engine and transmission functions and easy access to OEM vehicle service codes.
- Microprocessor based logic eliminates or reduces the need for auxiliary vehicle circuits, such as timing circuits.
- One hardware set can be instantly programmed into a wide range of OEM specified instrumentation for use in a variety of different vehicles.
- Large, easy-to-read dot matrix LCD is backlit for ideal viewing in all lighting conditions.
- Configure your own panel using the Curtis web-based specification tool to experience the full range of design possibilities.
- enGage™ IV replaces up to 4 gauges. OEMs can view up to 4 traditional gauge functions simultaneously in a variety of styles including numeric, bar or simulated needle.
- Up to 6 switched inputs are available to track status of critical vehicle parameters, such as over-temperature, parking break, low-fuel, etc.
- Displays can include multiple warning icons and an advisory line for hour meters, maintenance monitors and time-of-day clock.
- Provides more information, such as diagnostics to the operator, while eliminating unnecessary wiring.
- Password protected, enabled field-programming of maintenance monitoring, elapsed time and battery discharge profiles matches the panel to the specific user application.
- Visual warnings include flashing LCD icons and bargraph segments, and dual color warning LED.
- Three 1-Amp FETs are used to control OEM specified vehicle functions, such as alarms, lift-lockout, etc.
- For battery powered vehicles, innovative Curtis battery monitoring technology provide reliable state-of-charge information.
- It's easy for the operator to access and change parameters and display menus with accessible front panel buttons.

Global Industrial Products

3338 West Lake Ave
Glenview, IL 60026 USA
TEL (847) 901-4040
FAX (847) 901-4036

FEATURES *continued*

- IP65 rated front panel (IP 40 rear) assures performance in the harshest environments.
- Easy Snap-Fit design and integrated connector lowers production costs by eliminating traditional mounting hardware kits. (Optional mounting bracket available.)
- Available in a panel-mount housing or behind-panel module for OEM design flexibility.
- Reliable solid-state design means no moving parts to wear out.
- Attractive contemporary styling enhances vehicle design and maximizes readability.

SPECIFICATIONS

- Case and Bezel Material
ABS Polycarbonate Resin, black.
- Lens Material
PMMA.
- Module Specifications
All modules are supplied with critical components exposed. If the module is being used in an environment other than specified, the user must take precautions to package the module to provide adequate protection.
- Main Interface Connector
20-pin AMP Mini Universal Mate-N-Lok. (female mating AMP part number 770585-1).
- CAN & SIO Interface Connector
12-pin AMP Mini Universal Mate-N-Lok (female mating AMP part number 770581-1).
- Operating voltages
Auto-ranging -
12V to 80V DC \pm 25% (9V to 100V DC).
- Operating temperature
-40°C to +70°C.
- Storage temperature
-50°C to +90°C.
- Humidity (Applicable To Enclosed Units Only):
95% RH (non-condensing) at +38°C as per SAE J1455, section 4.2.3.
Note: Module requirements may be reduced.
- Mechanical Shock (Applicable To Enclosed Units Only):
SAE J 1378 March 83. Amplitude
44-55 g, half sine, 9-13 ms duration.
- Vibration (Applicable To Enclosed Units Only):
SAE J 1378 March 83 Double amplitude of 1.53mm with frequency sweep for 10-80-10 Hz (20 g max) at 1 minute intervals.
- Sealing (Applicable To Enclosed Units Only):
IP-65 (face), IP-40 (rear).
- Thermal Cycling
As per SAE J1455 section 4.1.3.1. to +80°C.
- Thermal Shock
As per SAE J1455 section 4.1.3.2. to +80°C.
- Salt Spray / Fog (Applicable To Enclosed Units Only):
ASTM B 117-73 as per SAE J1810, section 4.7.1.2.

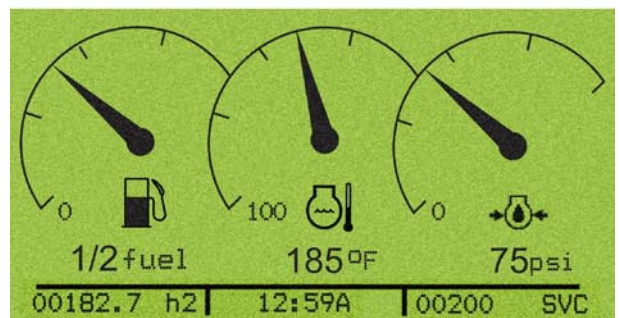
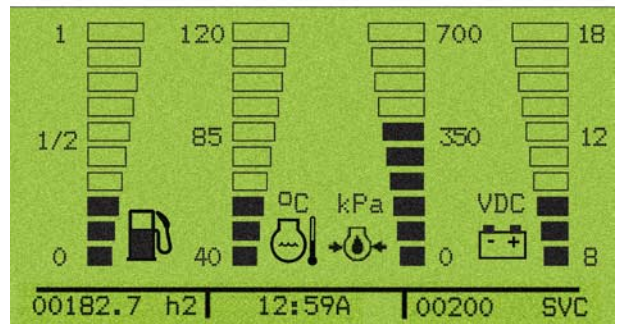
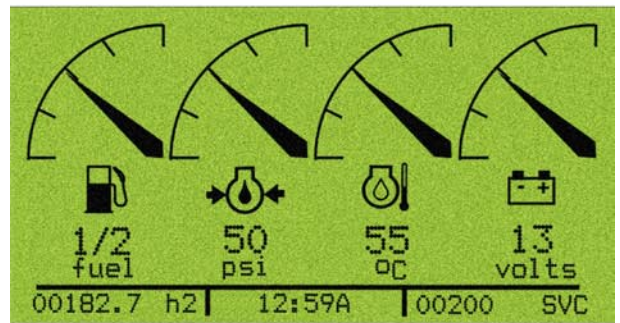
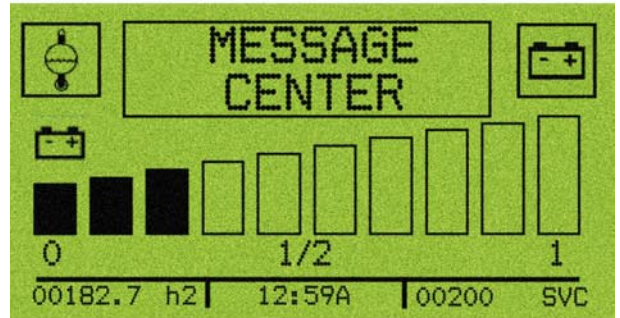
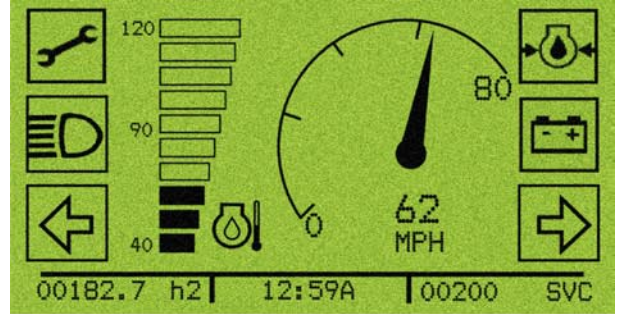

3200 SERIES

DIMENSIONS mm

3210T Cased Unit
Weight 400 g max

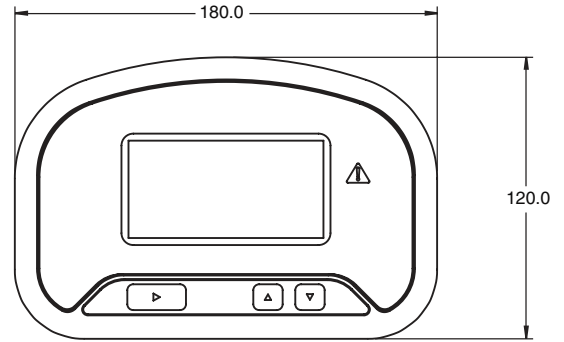
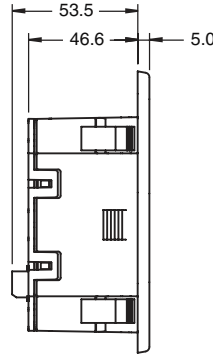
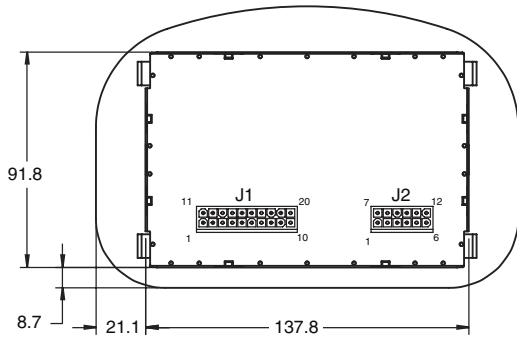

Recommended panel cutout: 92 (+0.8,-0) x 138 (+1.0,-0)mm
Acceptable panel thickness (snap-fit fingers): 0.8 to 3.8mm
Acceptable panel thickness (bracket): 5.0 to 8.9mm

3210P Module
Weight 200 g max

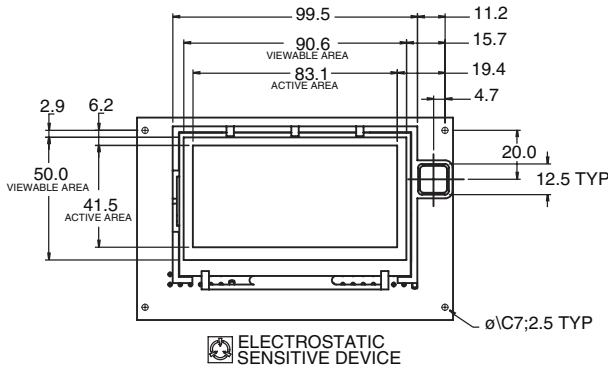
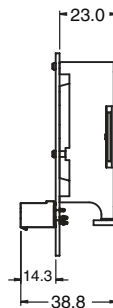
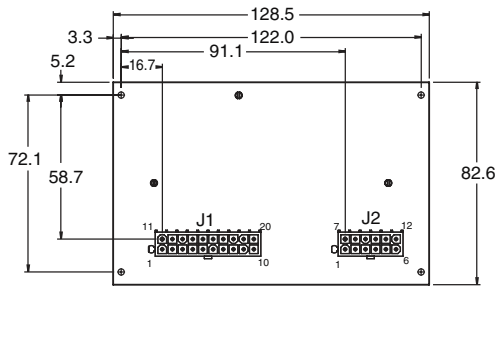

AMP MATING CONNECTORS		
	J1	J2
CONNECTOR	AMP P/N 770585-1	AMP P/N 770581-1
PIN	AMP P/N 770904-1 FOR 18-22 AWG WIRE	

CONNECTOR J1

PIN#	DESCRIPTION
1	Battery + (B+) - 12V-80V
2	Battery - (B-)
3	Sender 1 I/O (R, V, I)
4	Sender 2 I/O (R, V, I)
5	Sender 3 I/O (R, V, I)*
6	Sender 4 I/O (R, V, I) (3210T=**)
7	Switched Input 1
8	Switched Input 2
9	Switched Input 3
10	Switched Input 4
11	Switched Input 5
12	Switched Input 6
13	Keypad Input
14	MOSFET Output 1
15	MOSFET Output 2
16	MOSFET Output 3
17	3210T=Range select ***
17	3220T=NC
18	3210T=N/C
18	3220T=Sender 4**
19	LCD Heater
20	Dim Control

CONNECTOR J2

PIN#	DESCRIPTION
1	CAN H
2	CAN L
3	CAN Shield Ground
4	N/C
5	CAN Term 1
6	CAN Term 2
7	N/C
8	N/C
9	SCI - Rx
10	SCI Ground
11	SCI - Tx
12	+7V Out (<10 mA)

* INPUT FOR: SPEEDOMETER
** INPUT FOR: TACHOMETER
*** GND: 36V, 72V
B+: 24V, 60V
OPEN: 12V, 48V, 80V

MODEL ENCODEMENT

Model	Case	Voltage	Sequential	CAN Protocol
3210	T	12 – 80 VDC (Auto Ranging)	-0001	Open
3220	T	12 – 24 VDC	-0001	SAE J1939

WARRANTY Two year limited warranty from time of delivery.